

Izdaja 2026

Uprava in centralno skladišče

Sikla d.o.o.

Prekmurske čete 99

9232 Črenšovci

Telefon +386 (0)2 573 58 62

E-mail: info.si@sikla.com

Internet: www.sikla.si



Vsebina

1 siFramo 80

2 siFramo 100

3 Nosilni sistem 100

4 Nosilni sistem 120

5 Cevni ležaji

6 Objemke in sestavni deli

7 Pritrditev z verigo

8 Sklopi

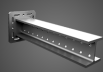
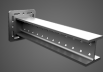
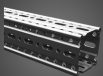
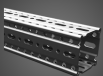

A

Adapter čelni STA 100	22
Adapter čelni STA 120	24
Adapter čelni STA F 100	13
Adapter čelni STA F 100 - 100/160	14
Adapter čelni STA F 100-80-E 45°	14
Adapter čelni STA F 160-100-E	13
Adapter čelni STA F 160-Q	14
Adapter čelni STA F 80	4
Adapter čelni STA F 80-E 45°	4
Adapter čelni STA F 80/30	3
Adapter čelni STA F 80/30 E	3
Adapter čelni STA F 80/30-Q	3
Adapter PK F 100 4kt HCP	19
Adapter PK F 100 8kt HCP	19
Adapter PK F 80 4kt HCP	8
Adapter PK F 80 8kt HCP	8
Adapter varilni HPA	44
Adapter za ograjo GLA F	41
Adapter za profil SA F 100	17
Adapter za profil SA F 80	6
Adapter-T TA 100	22
Adapter-T TA 120	25
Aksialni zapornik AS	31
Aksialni zapornik AS F	30
Aksialni zapornik variabilni VAS	32
Aksialni zapornik variabilni VAS F	31

B

Barva za popravke ABL HT	37
--------------------------	----

C

Cevni ležaj izolacijski LK - HV 150	29
Cevni ležaj LA - HV	27
Cevni ležaj LC - HV	28
Cevni ležaj LD - HV	29

D

Drnsni set FS	31
Drnsni set FW F	30
Drnsni set FW F L/Z	32
Drnsni set LR - H 20	32
Drnsnik GS F 1G	9, 16, 39
Drnsnik GS F 2G	9, 17, 39
Držalo osnovno SHB F 80	5
Držalo profila TPH F 100	19
Držalo profila TPH F 80	8
Držalo varilno ASA F 100 GPL 4kt	16
Držalo varilno ASA F 100 GPL 8kt	16
Držalo varilno ASA F 80 GPL 4kt	5
Držalo varilno ASA F 80 GPL 8kt	6
Držalo WBD F 100	14
Držalo WBD F 100/160	15
Držalo WBD F 80	4
Držalo za žerjav KLA F	1, 11

F

Fiksna točka XR - H 20 (DN15 - 50)	35
Fiksna točka XR - H 20 (DN65 - 300)	36
Fiksni set XS	31
Fiksni set XW F	30

K

Kavelj vpenjalni set FS Z	32
Komplet montažni MS 5P	7, 18, 23, 25
Komplet montažni MS 5P MA	7, 18, 23, 26
Konzola kotna SKO 100	22
Konzola kotna SKO F 100	12
Konzola kotna SKO F 80	2
Konzola nosilna TKO 100	21
Konzola nosilna TKO 120	24
Konzola nosilna TKO F 100	12
Konzola nosilna TKO F 100/160	12
Konzola nosilna TKO F 80	2
Konzola prečna QKO 100	21
Konzola prečna QKO 120	24
Konzola previsna AK F 100	11
Konzola previsna AK F 160-100-E	11
Konzola previsna AK F 80	1
Konzola previsna AK F 80/30	1
Konzola previsna AK F 80/30-Q	2
Kotnik WD F 100	17
Kotnik WD F 80	6

M

Matica podaljšana AD IG/IG HCP	46
Matica šestroba NT HCP	41
Montažni profil TP F 100	11
Montažni profil TP F 80	1

N

Navojna palica GST HCP	41, 46
Navojni zatič GST HCP	41, 45
Nosilni profil TP 100	21
Nosilni profil TP 120	24

O

Objemka izolacijska RB 175 EX	42
Objemka RUC I	38
Objemka Stabil Form C LK	46
Objemka Stabil I-1/2" HCP	38
Objemka Stabil I-1/2" VA	37
Osnovna plošča GPL F	7, 16, 40
Osnovna plošča GPL F Stabil HCP	9, 18
Osnovna plošča GPL Stabil HCP	40

P

Plošča adapter AP	5, 15, 22, 25
Plošča varilna SPL	10, 20
Plošča viseča HP 80/99	44
Plošča viseča HP F 100	45
Plošča viseča HP F 80	45
Podloga U-UB F	10, 40
Podnožje SHB SQF F 80	4
Podpora na strehi DF AV	5
Povezovalac FV 100/120	23, 25
Povezovalni set verige LKV	45
Pritrditev UB F	9, 19, 40
Pritrditev viseče plošče LKA	44
Profilna guma SAL EPDM sk	37

S

Samorezni vijak FLS F	6, 17
Sklop BG11 MS41-1/2"	47

Sklop BG11 MS41-M10	47	Sklop BG93 F80/100-1/2"	59
Sklop BG13 MS41-1/2"	48	Sklop BG94 MS41-1/2"	60
Sklop BG13 MS41-M10	47	Sklop BG95 MS41-1/2"	61
Sklop BG14 F80-1/2"	48	Sklop BG96 MS41-M10	62
Sklop BG14 F80-M10	48	Sklop BG97 MS41-1/2"	62
Sklop BG15 F80-1/2"	49	Sklop BG98 F80-1/2"	63
Sklop BG15 F80-M10	49	Sklop BG99 F80-1/2"	64
Sklop BG16 F100-1/2"	49	Streme navojno RUB DIN 3570 A HCP	39
Sklop BG17 F100-1/2"	50	Streme vpenjalno SB F 100	18
Sklop BG22 F100	50	Streme vpenjalno SB F 80	7
Sklop BG22 F80	50	Strešna podpora DF AH	15
Sklop BG42 MS41-1/2"	51	Strešna podpora DF AV	15
Sklop BG44 F80-1/2"	51		
Sklop BG45 F80-1/2"	52	T	
Sklop BG48 MS41-1/2"	52	Talna ploščica za hodnik FBT	42
Sklop BG49 F100-1/2"	53	Trak iz steklenih vlaken GSK	37
Sklop BG50 F100-1/2"	53		
Sklop BG51 F80	53	V	
Sklop BG52 F80/100	54	Vodilno ležišče FR – H 20 (DN15 - 50)	33
Sklop BG54 F100	54	Vodilno ležišče FR – H 20 (DN65 - 300)	34
Sklop BG57 MS41	54		
Sklop BG60 T100-1/2"	55	Z	
Sklop BG61 T100-1/2"	55	Zaključna kapica ADK 100	23
Sklop BG82 F80/100-1/2"	55	Zaključna kapica ADK 120	26
Sklop BG83 F80/100-M10	56	Zaključna kapica ADK F 100	20
Sklop BG84 F80/100-M10	56	Zaključna kapica ADK F 80	8
Sklop BG85 F80/100-1/2"	56	Zglob GE F 100	12
Sklop BG86 MS41-M10	57	Zglob GE F 100/160	13
Sklop BG87 MS41-1/2"	57	Zglob GE F 80	2
Sklop BG88 MS41-1/2"	57	Zglob GE ST - F 100	13
Sklop BG89 F80/100-1/2"	58	Zglob GE ST - F 80	3
Sklop BG90 MS41-M10	58		
Sklop BG91 MS41-1/2"	58	Š	
Sklop BG92 F80/100-M10	59	Šablona za izolacijo ISC	30

1 siFramo 80

1	1
Montažni profil TP F 80	1
Držalo za žerjav KLA F	1
Konzola previsna AK F 80	1
Konzola previsna AK F 80/30	1
Konzola previsna AK F 80/30-Q	2
Konzola nosilna TKO F 80	2
Konzola kotna SKO F 80	2
Zglob GE F 80	2
Zglob GE ST - F 80	3
Adapter čelni STA F 80/30	3
Adapter čelni STA F 80/30-Q	3
Adapter čelni STA F 80/30 E	3
Adapter čelni STA F 80	4
Adapter čelni STA F 80-E 45°	4
Držalo WBD F 80	4
Podnožje SHB SQF F 80	4
Držalo osnovno SHB F 80	5
Podpora na strehi DF AV	5
Plošča adapter AP	5
Držalo varilno ASA F 80 GPL 4kt	5
Držalo varilno ASA F 80 GPL 8kt	6
Kotnik WD F 80	6
Adapter za profil SA F 80	6
Samorezni vijak FLS F	6
Komplet montažni MS 5P	7
Komplet montažni MS 5P MA	7
Osnovna plošča GPL F	7
Streme vpenjalno SB F 80	7
Držalo profila TPH F 80	8
Adapter PK F 80 8kt HCP	8
Adapter PK F 80 4kt HCP	8
Zaključna kapica ADK F 80	8
Drsnik GS F 1G	9
Drsnik GS F 2G	9
Osnovna plošča GPL F Stabil HCP	9
Pritrditev UB F	9
Podloga U-UB F	10
Plošča varilna SPL	10

2 siFramo 100

11	11
Montažni profil TP F 100	11
Držalo za žerjav KLA F	11
Konzola previsna AK F 100	11
Konzola previsna AK F 160-100-E	11
Konzola nosilna TKO F 100	12
Konzola nosilna TKO F 100/160	12
Konzola kotna SKO F 100	12
Zglob GE F 100	12
Zglob GE ST - F 100	13
Zglob GE F 100/160	13
Adapter čelni STA F 100	13
Adapter čelni STA F 160-100-E	13
Adapter čelni STA F 100-80-E 45°	14
Adapter čelni STA F 100 - 100/160	14
Adapter čelni STA F 160-Q	14
Držalo WBD F 100	14
Držalo WBD F 100/160	15
Strešna podpora DF AH	15
Strešna podpora DF AV	15
Plošča adapter AP	15
Osnovna plošča GPL F	16

16	16
Držalo varilno ASA F 100 GPL 4kt	16
Držalo varilno ASA F 100 GPL 8kt	16
Držalo varilno ASA F 100 GPL 8kt	16
Drsnik GS F 1G	16
Drsnik GS F 2G	17
Kotnik WD F 100	17
Adapter za profil SA F 100	17
Samorezni vijak FLS F	17
Komplet montažni MS 5P	18
Komplet montažni MS 5P MA	18
Streme vpenjalno SB F 100	18
Osnovna plošča GPL F Stabil HCP	18
Držalo profila TPH F 100	19
Pritrditev UB F	19
Adapter PK F 100 8kt HCP	19
Adapter PK F 100 4kt HCP	19
Zaključna kapica ADK F 100	20
Plošča varilna SPL	20

3 Nosilni sistem 100

21	21
Nosilni profil TP 100	21
Konzola nosilna TKO 100	21
Konzola prečna QKO 100	21
Konzola kotna SKO 100	22
Adapter čelni STA 100	22
Adapter-T TA 100	22
Plošča adapter AP	22
Povezovalac FV 100/120	23
Komplet montažni MS 5P	23
Komplet montažni MS 5P MA	23
Zaključna kapica ADK 100	23

4 Nosilni sistem 120

25	25
Nosilni profil TP 120	25
Konzola nosilna TKO 120	25
Konzola prečna QKO 120	25
Adapter čelni STA 120	25
Adapter-T TA 120	26
Plošča adapter AP	26
Povezovalac FV 100/120	26
Komplet montažni MS 5P	26
Komplet montažni MS 5P MA	27
Zaključna kapica ADK 120	27

5 Cevni ležaji

28	28
Cevni ležaj LA - HV	28
Cevni ležaj LC - HV	29
Cevni ležaj LD - HV	30
Cevni ležaj izolacijski LK - HV 150	30
Šablona za izolacijo ISC	31
Drsnik set FW F	31
Fiksni set XW F	31
Aksialni zapornik AS F	31
Aksialni zapornik variabilni VAS F	32
Drsnik set FS	32
Fiksni set XS	32
Aksialni zapornik AS	32
Aksialni zapornik variabilni VAS	33
Kavelj vpenjalni set FS Z	33
Drsnik set FW F L/Z	33
Drsnik set LR - H 20	33

Vodilno ležišče FR – H 20 (DN15 - 50)	34		
Vodilno ležišče FR – H 20 (DN65 - 300)	35		
Vodilno ležišče FR – H 20 (DN65 - 300)	35		
Fiksna točka XR - H 20 (DN15 - 50)	36		
Fiksna točka XR - H 20 (DN65 - 300)	37		
Trak iz steklenih vlaken GSK	38		
Barva za popravke ABL HT	38		
Profilna guma SAL EPDM sk	38		
Objemka Stabil I-1/2" VA	38		
Objemka Stabil I-1/2" HCP	39		
Objemka RUC I	39		
6 Objemke in sestavni deli	40	8 Sklopi	48
Streme navojno RUB DIN 3570 A HCP	40	Sklop BG11 MS41-M10	48
Streme navojno RUB DIN 3570 A HCP	40	Sklop BG11 MS41-1/2"	48
Drsnik GS F 2G	40	Sklop BG13 MS41-M10	48
Drsnik GS F 1G	40	Sklop BG13 MS41-1/2"	49
Osnovna plošča GPL F	41	Sklop BG14 F80-M10	49
Osnovna plošča GPL Stabil HCP	41	Sklop BG14 F80-1/2"	49
Pritrditev UB F	41	Sklop BG15 F80-M10	50
Podloga U-UB F	41	Sklop BG15 F80-1/2"	50
Navojna palica GST HCP	42	Sklop BG16 F100-1/2"	50
Navojni zatič GST HCP	42	Sklop BG17 F100-1/2"	51
Matica šestroba NT HCP	42	Sklop BG22 F80	51
Adapter za ograjo GLA F	42	Sklop BG22 F100	51
Talna ploščica za hodnik FBT	43	Sklop BG42 MS41-1/2"	52
Objemka izolacijska RB 175 EX	43	Sklop BG44 F80-1/2"	52
		Sklop BG45 F80-1/2"	53
		Sklop BG48 MS41-1/2"	53
		Sklop BG49 F100-1/2"	54
		Sklop BG50 F100-1/2"	54
		Sklop BG51 F80	54
		Sklop BG52 F80/100	55
		Sklop BG54 F100	55
		Sklop BG57 MS41	55
		Sklop BG60 T100-1/2"	56
		Sklop BG61 T100-1/2"	56
		Sklop BG82 F80/100-1/2"	56
		Sklop BG83 F80/100-M10	57
		Sklop BG84 F80/100-M10	57
		Sklop BG85 F80/100-1/2"	57
		Sklop BG86 MS41-M10	58
		Sklop BG87 MS41-1/2"	58
		Sklop BG88 MS41-1/2"	58
		Sklop BG89 F80/100-1/2"	59
		Sklop BG90 MS41-M10	59
		Sklop BG91 MS41-1/2"	59
		Sklop BG92 F80/100-M10	60
		Sklop BG93 F80/100-1/2"	60
		Sklop BG94 MS41-1/2"	61
		Sklop BG95 MS41-1/2"	62
		Sklop BG96 MS41-M10	63
		Sklop BG97 MS41-1/2"	63
		Sklop BG98 F80-1/2"	64
		Sklop BG99 F80-1/2"	65
7 Pritrditev z verigo	45		
Plošča viseča HP 80/99	45		
Pritrditev viseče plošče LKA	45		
Adapter varilni HPA	45		
Plošča viseča HP F 80	46		
Plošča viseča HP F 100	46		
Povezovalni set verige LKV	46		
Navojni zatič GST HCP	46		
Navojna palica GST HCP	47		
Matica podaljšana AD IG/IG HCP	47		
Objemka Stabil Form C LK	47		

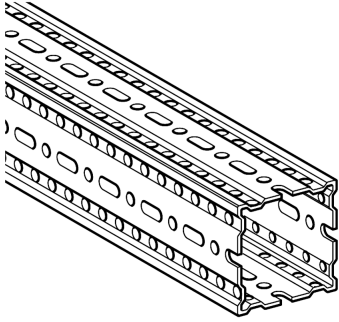
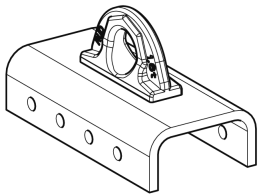
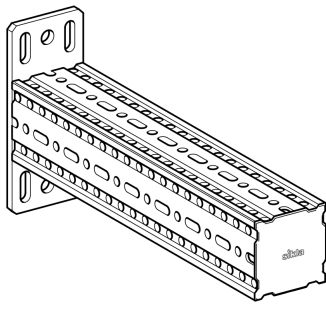
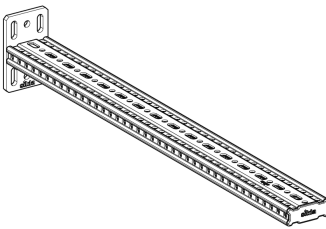
Produkt	Artikel	Pakirano	Artikel-št.
Montažni profil TP F 80 	Skupina: A410		
	TP F 80		192539
	TP F 80/30	6	113407
Držalo za žerjav KLA F 	Skupina: A430		
	KLA F 80	1	292874
	KLA F 100	1	292873
Konzola previsna AK F 80 	Skupina: A420		
	AK F 80-400	1	192764
	AK F 80-600	1	113170
	AK F 80-800	1	192771
	AK F 80-1000	1	113171
	AK F 80-E-600	1	110370
Konzola previsna AK F 80/30 	Skupina: A420		
	AK F 80/30-400	1	113064
	AK F 80/30-800	1	113065
	AK F 80/30-E-400	1	113625
	AK F 80/30-E-800	1	113626

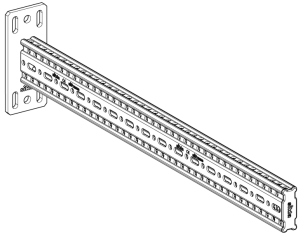
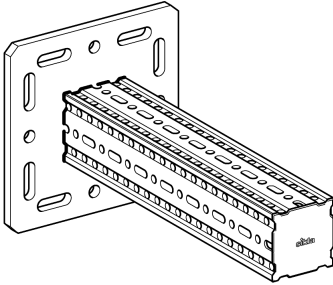
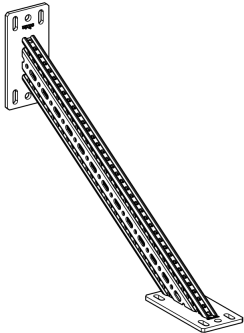
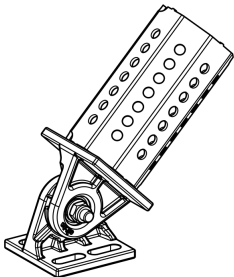

Produkt	Artikel	Pakirano	Artikel-št.
Konzola previsna AK F 80/30-Q 	Skupina: A420		
	AK F 80/30-Q-400	1	117292
	AK F 80/30-Q-800	1	117293
Konzola nosilna TKO F 80 	Skupina: A423		
	KO F 80-400	1	192788
	TKO F 80-600	1	113172
	TKO F 80-800	1	192795
	TKO F 80-1000	1	113173
Konzola kotna SKO F 80 	Skupina: A423		
	SKO F 80	1	117152
Zglob GE F 80 	Skupina: A437		
	GE F 80 - 80	1	113835
	GE F 80 - 80 q	1	113834

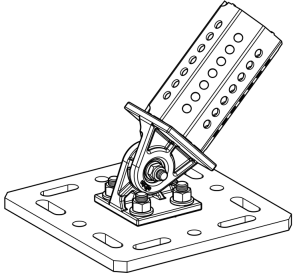
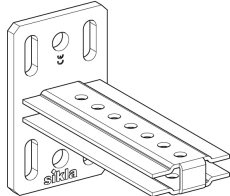
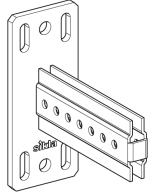
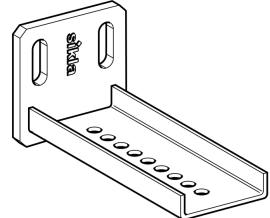
Produkt	Artikel	Pakirano	Artikel-št.
Zglob GE ST - F 80	Skupina: A437		
* na zalogi	GE 80/120-F 80 *	1	115856
	GE F 121/160-F 80	1	115857
	GE-Q 121/160-F 80	1	115858
	GE 161/200-F 80	1	115859
	GE-Q 161/200-F 80	1	115860
	GE 201/310-F 80	1	115861
	GE-Q 201/310-F 80	1	115862
Adapter čelni STA F 80/30	Skupina: A422		
	STA F 80/30	1	117160
Adapter čelni STA F 80/30-Q	Skupina: A422		
	STA F 80/30-Q	1	117294
Adapter čelni STA F 80/30 E	Skupina: A422		
	STA F 80/30-80-E	1	113066

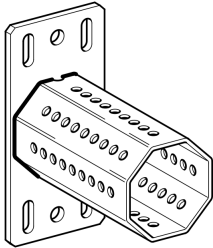
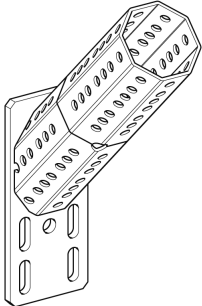
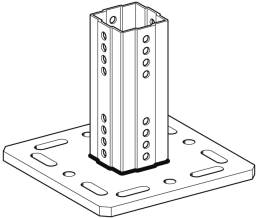
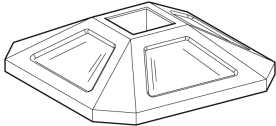

Produkt	Artikel	Pakirano	Artikel-št.
Adapter čelni STA F 80 	Skupina: A422		
	STA F 80 - T	1	192856
	STA F 80-E - L	1	192863
Adapter čelni STA F 80-E 45° 	Skupina: A422		
	STA F 80-E 45°	1	406001
Držalo WBD F 80 	Skupina: A421		
	WBD F 80-80/120	1	192801
	WBD-P F 80-121/160	1	117164
	WBD-P F 80-161/200	1	117165
	WBD-P F 80-201/310	1	117166
	WBD F 80-T	1	192849
Podnožje SHB SQF F 80 	Skupina: A440		
	SHB SQF F 80-350	1	218865
	SHB SQF F 80-500	1	218868

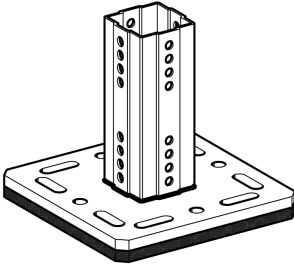
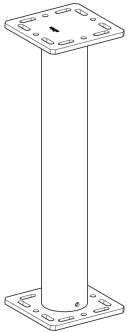
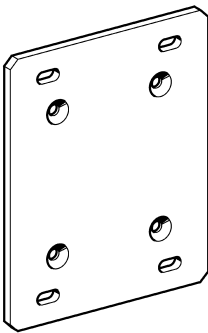
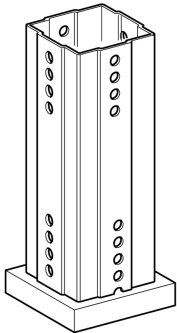
Produkt	Artikel	Pakirano	Artikel-št.
Držalo osnovno SHB F 80 	Skupina: A440		
	SHB F 80-220	1	198926
Podpora na strehi DF AV 	Skupina: A442		
	DF AV	1	117170
Plošča adapter AP 	Skupina: A630		
	AP 121/160	1	183953
	AP 161/200	1	183962
	AP 201/240	1	116534
	AP 241/310	1	117767
Držalo varilno ASA F 80 GPL 4kt 	Skupina: A428		
	ASA F 80 GPL 4kt	1	111741

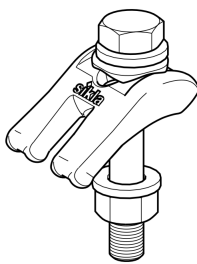
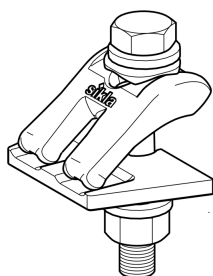
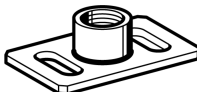
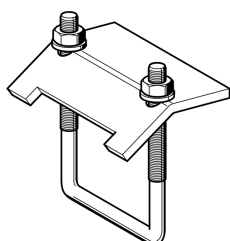

Produkt	Artikel	Pakirano	Artikel-št.
Komplet montažni MS 5P 	Skupina: A640		
	M12 S	10	115843
	M16 S	10	115844
	M12 S2	10	115845
Komplet montažni MS 5P MA 	Skupina: A640		
	M12 MA S	10	114886
	M16 MA S	10	114887
Osnovna plošča GPL F 	Skupina: A838		
	GPL F 80-1/2"	50	192900
	GPL F 80-M10	50	113004
	GPL F 80-M12	50	112911
	GPL F 80-M16	50	195833
	GPL F 100-1/2"	50	113089
	GPL F 100-M10	50	113338
	GPL F 100-M12	50	113646
	GPL F 100-M16	50	113090
	Streme vpenjalno SB F 80 	Skupina: A439	
SB F 80-16		20	192683
SB F 80-40		10	194010
SB F 80/30-16		20	115840
SB F 80/30-40		10	115839

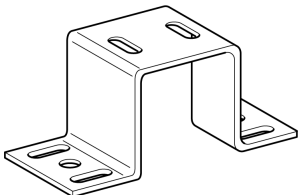
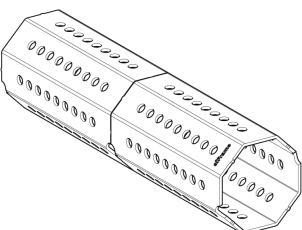
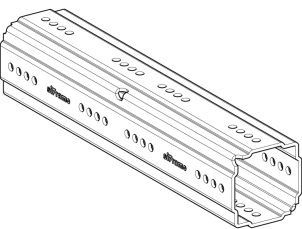
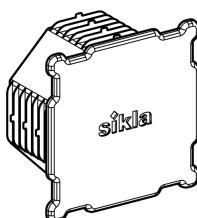

Produkt	Artikel	Pakirano	Artikel-št.
Držalo profila TPH F 80 	Skupina: A425		
	TPH F 80/30	10	116672
	TPH F 80/30 C	10	116673
	TPH F 80	10	195765
	TPH F 80 C	10	111732
Adapter PK F 80 8kt HCP 	Skupina: A430		
	PK F 80 8kt	1	111446
Adapter PK F 80 4kt HCP 	Skupina: A430		
	PK F 80 4kt	1	111445
Zaključna kapica ADK F 80 	Skupina: A430		
	ADK F 80	25	192674
	ADK F 80/30	25	113067

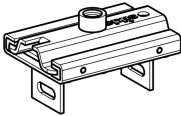
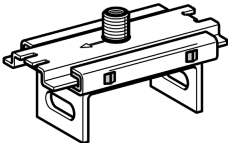
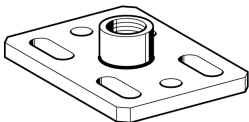
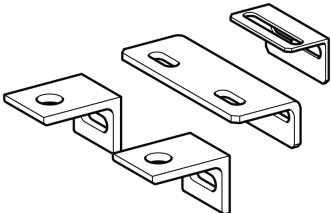
Produkt	Artikel	Pakirano	Artikel-št.
Drsnik GS F 1G 	Skupina: A436		
	GS F 80 1G	10	113885
	GS F 80 1G2	10	113886
	GS F 100 1G	10	113091
	GS F 100 1G2	10	113092
Drsnik GS F 2G 	Skupina: A436		
	GS F 80 2G	10	196700
	GS F 80 2G2	10	196717
	GS F 100 2G2	10	113093
Osnovna plošča GPL F Stabil HCP 	Skupina: A438		
	GPL F 80 ST-1/2"	25	112719
	GPL F 100 ST-1/2"	25	117266
	GPL F 100 ST-1"	25	117268
Pritrditev UB F 	Skupina: A430		
	UB F 1/2" - 1 1/2"	25	192931
	UB F 2" - 3"	10	196212
	UB F 4" - 6"	20	113124
	UB F 8" - 12"	20	113125
	UB F 378 - 530	20	113126

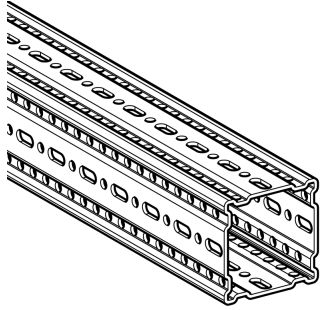
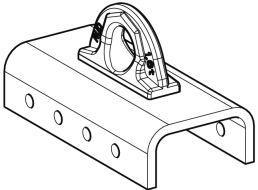
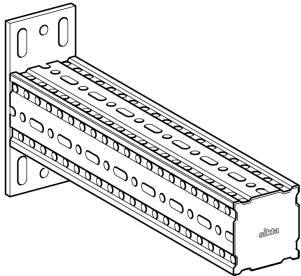
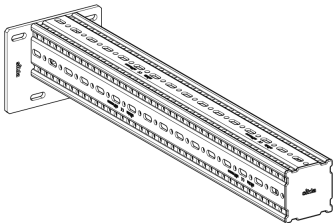

Produkt	Artikel	Pakirano	Artikel-št.
Montažni profil TP F 100 	Skupina: A810		
	TP F 100	6	112904
	TP F 100/160	6	112905
Držalo za žerjav KLA F 	Skupina: A430		
	KLA F 80	1	292874
	KLA F 100	1	292873
Konzola previsna AK F 100 	Skupina: A820		
	AK F 100-400	1	113068
	AK F 100-800	1	113069
	AK F 100-1200	1	113419
	AK F 100-E-600	1	113070
	AK F 100-80 - 400	1	117143
	AK F 100-80 - 800	1	117144
	AK F 100-80-E - 600	1	117254
Konzola previsna AK F 160-100-E 	Skupina: A820		
	AK F 160-100-E-800	1	117145
	AK F 160-100-E-1200	1	117146

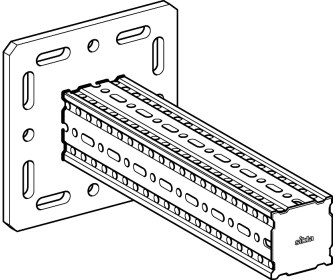
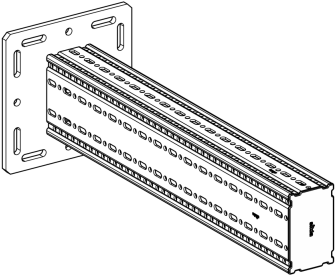
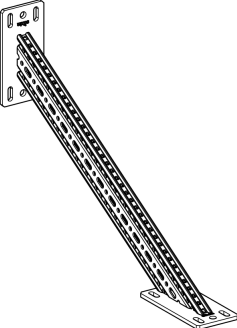
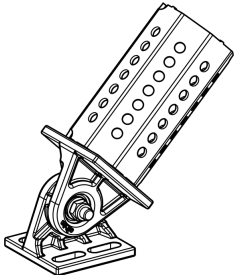

Produkt	Artikel	Pakirano	Artikel-št.
Konzola nosilna TKO F 100 	Skupina: A823		
	TKO F 100-400	1	113071
	TKO F 100-800	1	113072
	TKO F 100-1200	1	113421
Konzola nosilna TKO F 100/160 	Skupina: A823		
	TKO F 100/160-800	1	113097
	TKO F 100/160-1200	1	113420
Konzola kotna SKO F 100 	Skupina: A823		
	SKO F 100	1	113096
Zglob GE F 100 	Skupina: A437		
	GE F 100 - 80	1	113838
	GE F 100 - 80 q	1	113032
	GE F 100 - 100	1	113837
	GE F 100 - 100 q	1	113836

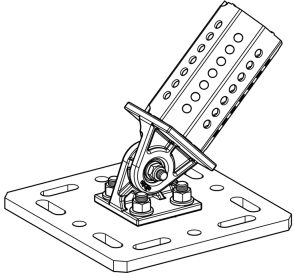
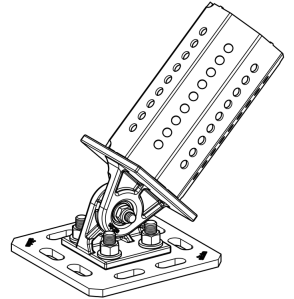
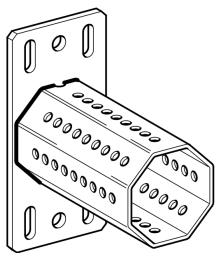
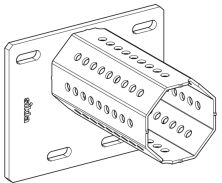

Produkt	Artikel	Pakirano	Artikel-št.
Zglob GE ST - F 100	Skupina: A437		
* na zalogi	GE 80/120-F 100 *	1	115863
	GE 121/160-F 100	1	115864
	GE-Q 121/160-F 100	1	115865
	GE 161/200-F 100	1	115866
	GE-Q 161/200-F 100	1	115867
	GE 201/310-F 100	1	115868
	GE-Q 201/310-F 100	1	115869
Zglob GE F 100/160	Skupina: A437		
	GE F 160 - 80	1	115854
	GE F 160 - 100	1	115855
Adapter čelni STA F 100	Skupina: A822		
	STA F 100	1	113073
	STA F 100-E	1	113074
	STA F 100-80	1	113337
	STA F 100-80-E	1	113481
Adapter čelni STA F 160-100-E	Skupina: A822		
	STA F 160-100-E	1	116875

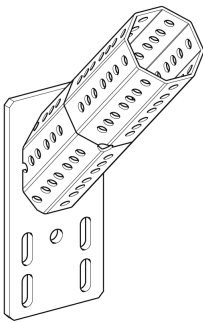
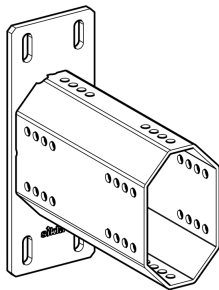
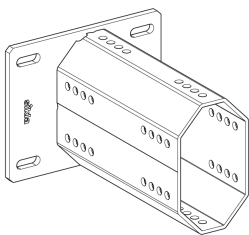
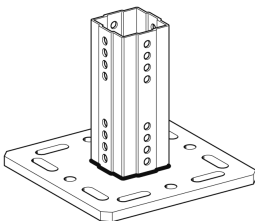

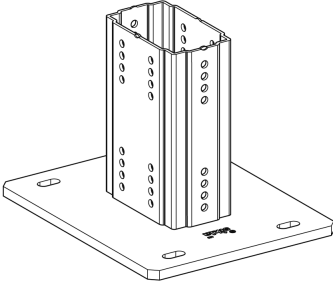
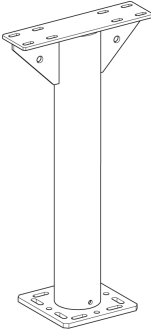
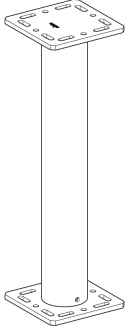
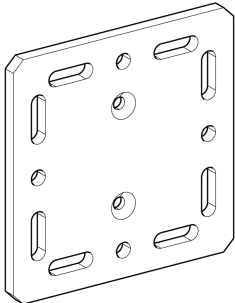
Produkt	Artikel	Pakirano	Artikel-št.
Adapter čelni STA F 100-80-E 45° 	Skupina: A822		
	STA F 100-80-E 45°	1	406002
Adapter čelni STA F 100 - 100/160 	Skupina: A822		
	STA F 100 - 100/160	1	114878
	STA F 100 - 100/160 E	1	114879
Adapter čelni STA F 160-Q 	Skupina: A822		
	STA F 160-Q	1	117147
Držalo WBD F 100 	Skupina: A821		
	WBD F 100-80/120	1	113075
	WBD-P F 100-121/160	1	117167
	WBD-P F 100-161/200	1	117168
	WBD-P F 100-201/310	1	117169
	WBD F 100-T	1	113079

Produkt	Artikel	Pakirano	Artikel-št.
Držalo WBD F 100/160 	Skupina: A821		
	WBD F100/160-121/160	1	113098
	WBD F100/160-161/200	1	113099
	WBD F100/160-201/300	1	113100
Strešna podpora DF AH 	Skupina: A442		
	DF AH	1	117171
Strešna podpora DF AV 	Skupina: A442		
	DF AV	1	117170
Plošča adapter AP 	Skupina: A630		
	AP 121/160	1	183953
	AP 161/200	1	183962
	AP 201/240	1	116534
	AP 241/310	1	117767

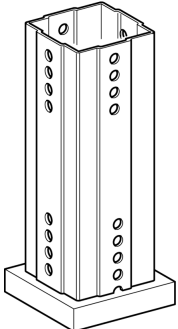
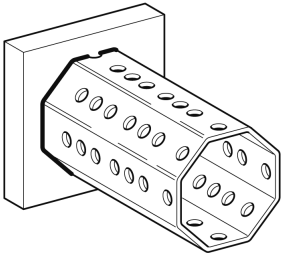

Produkt	Artikel	Pakirano	Artikel-št.
Osnovna plošča GPL F 	Skupina: A838		
	GPL F 80-1/2"	50	192900
	GPL F 80-M10	50	113004
	GPL F 80-M12	50	112911
	GPL F 80-M16	50	195833
	GPL F 100-1/2"	50	113089
	GPL F 100-M10	50	113338
	GPL F 100-M12	50	113646
	GPL F 100-M16	50	113090
Držalo varilno ASA F 100 GPL 4kt 	Skupina: A828		
	ASA F 100 GPL 4kt	1	113339
	ASA F 100/160 GPL 4kt	1	113410
Držalo varilno ASA F 100 GPL 8kt 	Skupina: A828		
	ASA F 100 GPL 8kt	1	113080
Drsnik GS F 1G 	Skupina: A436		
	GS F 80 1G	10	113885
	GS F 80 1G2	10	113886
	GS F 100 1G	10	113091
	GS F 100 1G2	10	113092

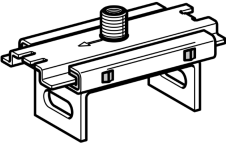
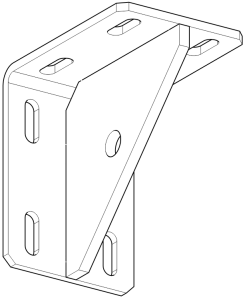
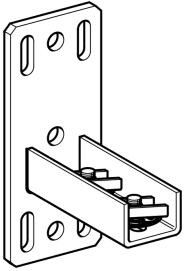
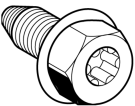
Produkt	Artikel	Pakirano	Artikel-št.
Drnsnik GS F 2G 	Skupina: A436		
	GS F 80 2G	10	196700
	GS F 80 2G2	10	196717
	GS F 100 2G2	10	113093
Kotnik WD F 100 	Skupina: A430		
	WD F 100 140/140	1	113095
Adapter za profil SA F 100 	Skupina: A827		
	SA F 100-41	1	113081
Samorezni vijak FLS F 	Skupina: A430		
	FLS F	100	192512

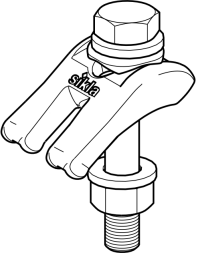
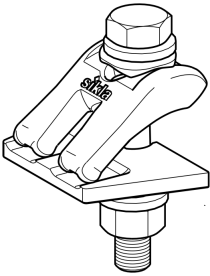
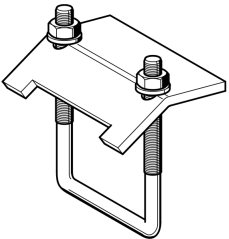
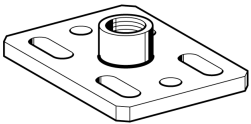

Produkt	Artikel	Pakirano	Artikel-št.
Komplet montažni MS 5P 	Skupina: A640		
	M12 S	10	115843
	M16 S	10	115844
	M12 S2	10	115845
Komplet montažni MS 5P MA 	Skupina: A640		
	M12 MA S	10	114886
	M16 MA S	10	114887
Streme vpenjalno SB F 100 	Skupina: A839		
	SB F 100-16	20	113082
	SB F 100-40	10	113083
	SB F 100/160-40	10	113101
Osnovna plošča GPL F Stabil HCP 	Skupina: A438		
	GPL F 80 ST-1/2"	25	112719
	GPL F 100 ST-1/2"	25	117266
	GPL F 100 ST-1"	25	117268

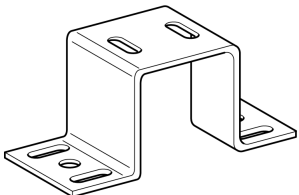
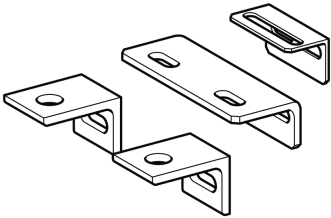
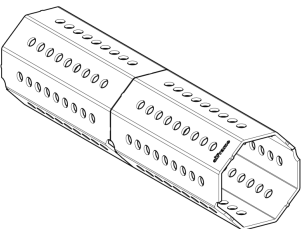
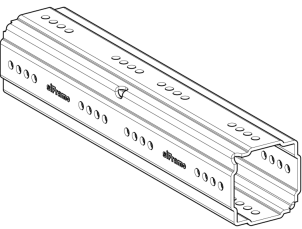
Produkt	Artikel	Pakirano	Artikel-št.
Držalo profila TPH F 100	Skupina: A825		
	TPH F 100 C	10	113084
	TPH F 100/80 C	10	113085
			
Pritrditev UB F	Skupina: A430		
	UB F 1/2" - 1 1/2"	25	192931
	UB F 2" - 3"	10	196212
	UB F 4" - 6"	20	113124
	UB F 8" - 12"	20	113125
	UB F 378 - 530	20	113126
			
Adapter PK F 100 8kt HCP	Skupina: A430		
	PK F 100 8kt	1	400389
			
Adapter PK F 100 4kt HCP	Skupina: A430		
	PK F 100 4kt	1	400390
			

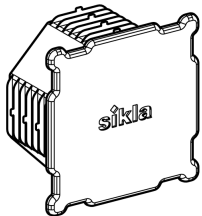
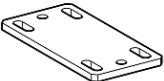
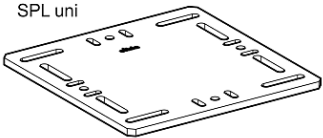

Produkt	Artikel	Pakirano	Artikel-št.
Zaključna kapica ADK F 100	Skupina: A430		
	ADK F 100	25	113086
	ADK F 100/160	25	113102
Plošča varilna SPL	Skupina: A430		
SPL F 80	SPL F 80	1	117833
	SPL F 100	1	117834
SPL uni	SPL universal	1	113636
			

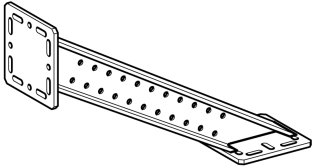
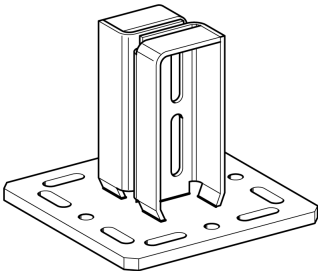
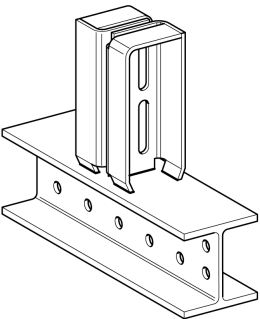
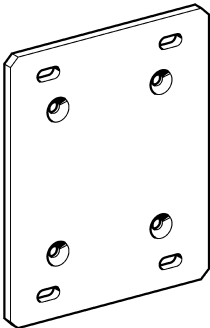
Produkt	Artikel	Pakirano	Artikel-št.
Konzola kotna SKO 100	Skupina: A622		
	SKO 100-30 x 760	1	191531
			
Adapter čelni STA 100	Skupina: A630		
	STA 100	1	183971
			
Adapter-T TA 100	Skupina: A630		
	TA 100 x 200	1	191081
	TA 100 x 400	1	191166
	TA 100 x 600	1	191099
			
Plošča adapter AP	Skupina: A630		
	AP 121/160	1	183953
	AP 161/200	1	183962
	AP 201/240	1	116534
	AP 241/310	1	117767
			

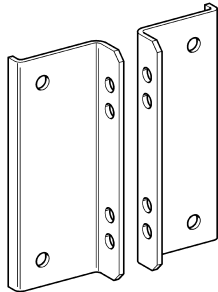
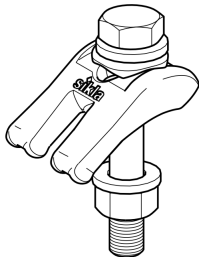
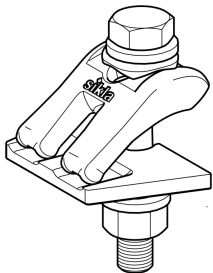
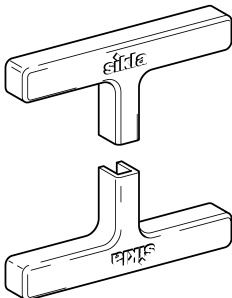
Produkt	Artikel	Pakirano	Artikel-št.
Povezovalc FV 100/120 	Skupina: A630		
	FV 100/120	1	187616
Komplet montažni MS 5P 	Skupina: A640		
	M12 S	10	115843
	M16 S	10	115844
	M12 S2	10	115845
Komplet montažni MS 5P MA 	Skupina: A640		
	M12 MA S	10	114886
	M16 MA S	10	114887
Zaključna kapica ADK 100 	Skupina: A630		
	ADK 100	50	190433

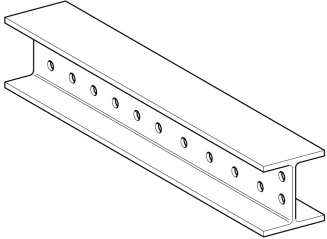
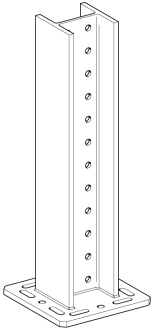
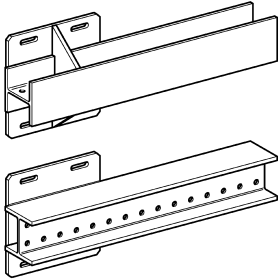
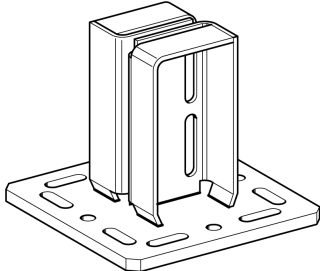

Produkt	Artikel	Pakirano	Artikel-št.
Nosilni profil TP 120 	Skupina: A600		
	TP 120	6	117355
Konzola nosilna TKO 120 	Skupina: A620		
	TKO 120 x 350	1	193150
	TKO 120 x 600	1	193167
	TKO 120 x 800	1	193174
	TKO 120 x 1000	1	193181
	TKO 120 x 1500	1	193198
	TKO 120 x 2000	1	193204
	TKO 120 x 3000	1	193105
Konzola prečna QKO 120 	Skupina: A624		
	QKO 120 x 600	1	193228
	QKO 120 x 1000	1	193235
	QKO 120q x 600	1	193242
QKO 120q x 1000	1	193259	
Adapter čelni STA 120 	Skupina: A630		
	STA 120	1	193211

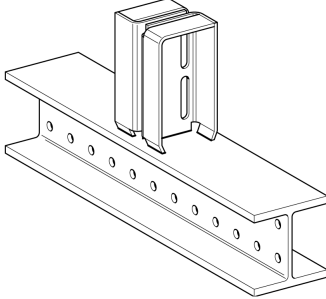
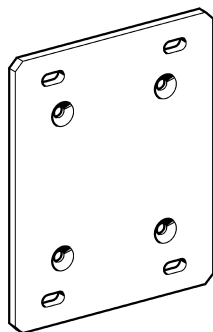
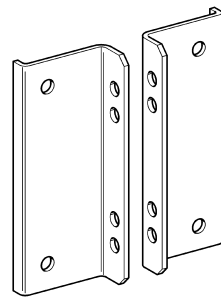
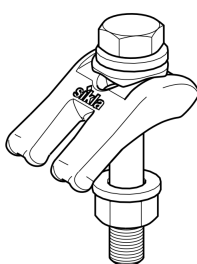
Produkt	Artikel	Pakirano	Artikel-št.
Adapter-T TA 120 	Skupina: A630		
	TA 120 x 200	1	193112
	TA 120 x 400	1	193129
	TA 120 x 600	1	193136
Plošča adapter AP 	Skupina: A630		
	AP 121/160	1	183953
	AP 161/200	1	183962
	AP 201/240	1	116534
	AP 241/310	1	117767
Povezovalc FV 100/120 	Skupina: A630		
	FV 100/120	1	187616
Komplet montažni MS 5P 	Skupina: A640		
	M12 S	10	115843
	M16 S	10	115844
	M12 S2	10	115845

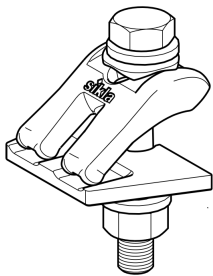
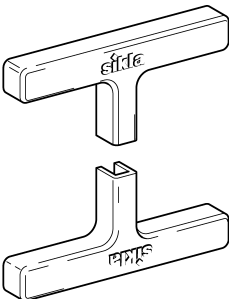

Produkt	Artikel	Pakirano	Artikel-št.
Komplet montažni MS 5P MA	Skupina: A640		
	M12 MA S	10	114886
	M16 MA S	10	114887
Zaključna kapica ADK 120	Skupina: A630		
	ADK 120	50	173189

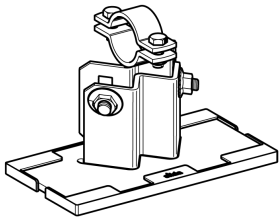
Produkt	Artikel	Pakirano	Artikel-št.
	Skupina: A731, A730, A732		
	LA - HV 90 18-22 (DN 15) 1/2"	1	112386
	LA - HV 90 23-27 (DN 20) 3/4"	1	112387
	LA - HV 90 30-34 (DN 25) 1"	1	110035
	LA - HV 90 40-44 (DN 32) 1 1/4"	1	110036
	LA - HV 90 45-49 (DN 40) 1 1/2"	1	110037
	LA - HV 90 57-61 (DN 50) 2"	1	110038
	LA - HV 90 72-77 (DN 65) 2 1/2"	1	110039
	LA - HV 90 84-89 (DN 80) 3"	1	110040
	LA - HV 90 109-115 (DN 100) 4"	1	110041
	LA - HV 90 134-140 (DN 125) 5"	1	110042
	LA - HV 90 163-169 (DN 150) 6"	1	110043
	LA - HV 150 18-22 (DN 15) 1/2"	1	112388
	LA - HV 150 23-27 (DN 20) 3/4"	1	112389
	LA - HV 150 30-34 (DN 25) 1"	1	110044
	LA - HV 150 40-44 (DN 32) 1 1/4"	1	110045
	LA - HV 150 45-49 (DN 40) 1 1/2"	1	110046
	LA - HV 150 57-61 (DN 50) 2"	1	110047
	LA - HV 150 72-77 (DN 65) 2 1/2"	1	110048
	LA - HV 150 84-89 (DN 80) 3"	1	110049
	LA - HV 150 109-115 (DN 100) 4"	1	110050
	LA - HV 150 134-140 (DN 125) 5"	1	110051
	LA - HV 150 163-169 (DN 150) 6"	1	110052
	LA - HV 200 18-22 (DN 15) 1/2"	1	112390
	LA - HV 200 23-27 (DN 20) 3/4"	1	112391
	LA - HV 200 30-34 (DN 25) 1"	1	110053
	LA - HV 200 40-44 (DN 32) 1 1/4"	1	110054
	LA - HV 200 45-49 (DN 40) 1 1/2"	1	110055
	LA - HV 200 57-61 (DN 50) 2"	1	110056
	LA - HV 200 72-77 (DN 65) 2 1/2"	1	110057
	LA - HV 200 84-89 (DN 80) 3"	1	110058
	LA - HV 200 109-115 (DN 100) 4"	1	110059
LA - HV 200 134-140 (DN 125) 5"	1	110060	
LA - HV 200 163-169 (DN 150) 6"	1	110061	



Produkt

Artikel

Pakirano

Artikel-št.

Cevni ležaj LD - HV

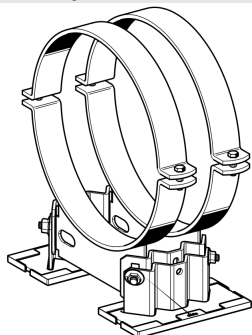

Skupina: A731, A730, A732

LD - HV 90 215-221 (DN 200) 8"	1	112398
LD - HV 90 266-273 (DN 250) 10"	1	112399
LD - HV 90 317-324 (DN 300) 12"	1	112400
LD - HV 90 349-356 (DN 350) 14"	1	110098
LD - HV 90 397-407 (DN 400) 16"	1	110099
LD - HV 90 498-508 (DN 500) 20"	1	110100
LD - HV 90 600-610 (DN 600) 24"	1	110101
LD - HV 150 215-221 (DN 200) 8"	1	112401
LD - HV 150 266-273 (DN 250) 10"	1	112402
LD - HV 150 317-324 (DN 300) 12"	1	112403
LD - HV 150 349-356 (DN 350) 14"	1	110102
LD - HV 150 397-407 (DN 400) 16"	1	110103
LD - HV 150 498-508 (DN 500) 20"	1	110104
LD - HV 150 600-610 (DN 600) 24"	1	110105
LD - HV 200 215-221 (DN 200) 8"	1	112404
LD - HV 200 266-273 (DN 250) 10"	1	112405
LD - HV 200 317-324 (DN 300) 12"	1	112406
LD - HV 200 349-356 (DN 350) 14"	1	110106
LD - HV 200 397-407 (DN 400) 16"	1	110107
LD - HV 200 498-508 (DN 500) 20"	1	110108
LD - HV 200 600-610 (DN 600) 24"	1	110109

Cevni ležaj izolacijski LK - HV 150

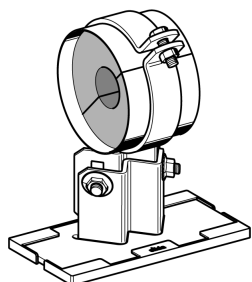

Skupina: A734

LK - HV 150 DN 25	1	110110
LK - HV 150 DN 32	1	110111
LK - HV 150 DN 40	1	110112
LK - HV 150 DN 50	1	110113
LK - HV 150 DN 65	1	110114
LK - HV 150 DN 80	1	110115
LK - HV 150 DN 100	1	110116
LK - HV 150 DN 125	1	110117
LK - HV 150 DN 150	1	110118
LK - HV 150 DN 200	1	110119
LK - HV 150 DN 250	1	110120
LK - HV 150 DN 300	1	110121



Produkt	Artikel	Pakirano	Artikel-št.
Šablona za izolacijo ISC	Skupina: A705		
	ISC LC/LD	25	113333
Drсни set FW F	Skupina: A705		
	FW F 80	1	110349
	FW F 100	1	113088
Fiksni set XW F	Skupina: A705		
	XW F 80	1	110356
	XW F 100	1	113087
Aksialni zapornik AS F	Skupina: A705		
	AS F 80	1	802787
	AS F 100	1	802788

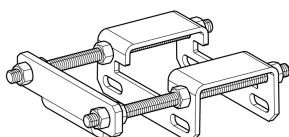
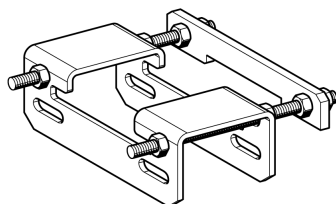
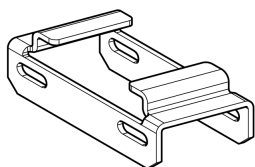
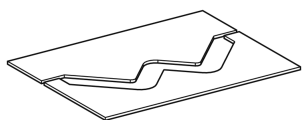

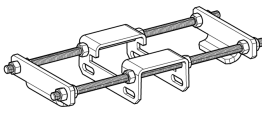
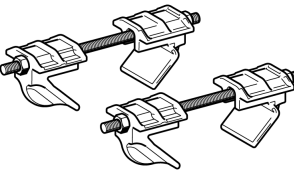
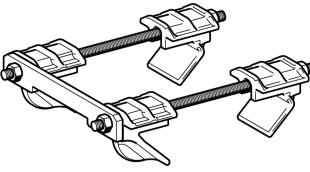
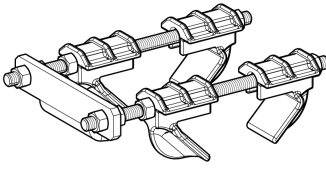
Produkt	Artikel	Pakirano	Artikel-št.
Aksialni zapornik variabilni VAS F	Skupina: A705		
	VAS F 80	1	802789
	VAS F 100	1	802790
			
Drсни set FS	Skupina: A705		
	FS 80/120	1	110350
	FS 140/160	1	110351
	FS 180/220	1	110352
	FS 240/260	1	110353
	FS 280/300	1	112887
			
Fiksni set XS	Skupina: A705		
	XS 80/120	1	110357
	XS 140/160	1	110358
	XS 180/220	1	110359
	XS 240/260	1	110360
	XS 280/300	1	110361
			
Aksialni zapornik AS	Skupina: A705		
	AS 80/120	1	802791
	AS 140/180	1	802792
	AS 240/260	1	802794
	AS 280/300	1	802795
			

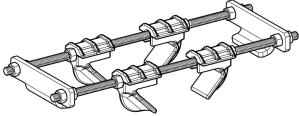
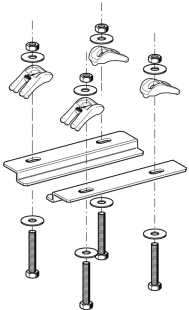
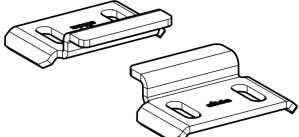
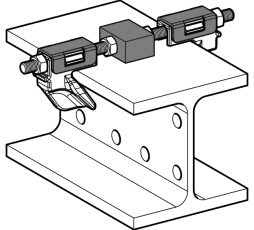

Produkt	Artikel	Pakirano	Artikel-št.
Aksialni zapornik variabilni VAS	Skupina: A705		
	VAS 80/140	1	802796
	VAS 160/260	1	802799
	VAS 280/300	1	802800
			
Kavelj vpenjalni set FS Z	Skupina: A705		
	FS Z 80/120	1	110398
			
Drnsni set FW F L/Z	Skupina: A705		
	FW F 80 Z 6	25	113628
	FW F 80 Z 9	25	113629
	FW F 80 Z 12 *	25	113630
	FW F 80 Z 15	25	113975
	FW F 80 L	25	113627
	FW F 100 Z 9	25	113633
	FW F 100 Z 12 *	25	113634
	FW F 100 Z 15	25	113976
	FW F 100 L	25	113631
			
Drnsni set LR - H 20	Skupina: A710		
	LR - H 20 30-80/120 *	10	113647
	LR - H 20 30-140/160	1	113648
	LR - H 20 30-180/220	1	113649
	LR - H 20 30-240/260	1	113650
	LR - H 20 30-280/300	1	113651
	LR - H 20 100-80/120 *	10	113653
	LR - H 20 100-140/160	1	113654
	LR - H 20 100-180/220	1	113655
	LR - H 20 100-240/260	1	113656
	LR - H 20 100-280/300	1	113657
			

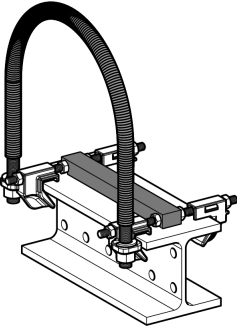
Produkt	Artikel	Pakirano	Artikel-št.
 <p>Vodilno ležišče FR – H 20 (DN65 - 300)</p>	Skupina: A740		
	FR - H 20 DN 65 - 140/160	1	113692
	FR - H 20 DN 65 - 180/220	1	113693
	FR - H 20 DN 65 - 240/260	1	113694
	FR - H 20 DN 65 - 280/300	1	113695
	FR - H 20 DN 80 - 80/120 *	5	113696
	FR - H 20 DN 80 - 180/220	1	113699
	FR - H 20 DN 80 - 240/260	1	113700
	FR - H 20 DN 80 - 280/300	1	113701
	FR - H 20 DN 100 - 80/120 *	5	113702
	FR - H 20 DN 100 - 180/220	1	113705
	FR - H 20 DN 100 - 240/260	1	113706
	FR - H 20 DN 100 - 280/300	1	113707
	FR - H 20 DN 125 - 80/120 *	5	113708
	FR - H 20 DN 125 - 180/220	1	113710
	FR - H 20 DN 125 - 240/260	1	113711
	FR - H 20 DN 125 - 280/300	1	113712
	FR - H 20 DN 150 - 80/120 *	5	113713
	FR - H 20 DN 150 - 140/160	1	113714
	FR - H 20 DN 150 - 180/220	1	113715
	FR - H 20 DN 150 - 240/260	1	113716
	FR - H 20 DN 150 - 280/300	1	113717
	FR - H 20 DN 175 - 80/120	5	113718
	FR - H 20 DN 175 - 140/160	1	113719
	FR - H 20 DN 175 - 180/220	1	113720
	FR - H 20 DN 175 - 240/260	1	113721
	FR - H 20 DN 175 - 280/300	1	113722
	FR - H 20 DN 200 - 80/120 *	5	113723
	FR - H 20 DN 200 - 140/160	1	113724
	FR - H 20 DN 200 - 180/220	1	113725
	FR - H 20 DN 200 - 240/260	1	113726
	FR - H 20 DN 200 - 280/300	1	113727
	FR - H 20 DN 225 - 80/120	5	113728
	FR - H 20 DN 225 - 140/160	1	113729
	FR - H 20 DN 225 - 180/220	1	113730
	FR - H 20 DN 225 - 240/260	1	113732
	FR - H 20 DN 225 - 280/300	1	113733
	FR - H 20 DN 250 - 80/120	5	113734
	FR - H 20 DN 250 - 140/160	1	113735
	FR - H 20 DN 250 - 180/220	1	113736
	FR - H 20 DN 250 - 240/260	1	113737
	FR - H 20 DN 250 - 280/300	1	113738
FR - H 20 DN 300 - 80/120	5	113739	
FR - H 20 DN 300 - 140/160	1	113740	
FR - H 20 DN 300 - 180/220	1	113741	
FR - H 20 DN 300 - 240/260	1	113742	
FR - H 20 DN 300 - 280/300	1	113743	

Produkt

Artikel

Pakirano

Artikel-št.

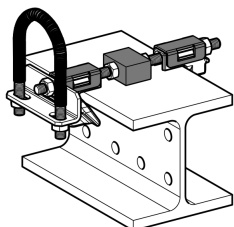

Fiksna točka XR - H 20 (DN15 - 50)



Skupina: A770

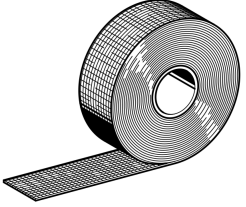

XR - H 20 DN 15 - 280/300	1	113748
XR - H 20 DN 20 - 80/120	10	113749
XR - H 20 DN 20 - 140/160	1	113750
XR - H 20 DN 20 - 180/220	1	113751
XR - H 20 DN 20 - 240/260	1	113752
XR - H 20 DN 20 - 280/300	1	113753
XR - H 20 DN 25 - 80/120 *	10	113754
XR - H 20 DN 25 - 140/160	1	113755
XR - H 20 DN 25 - 180/220	1	113756
XR - H 20 DN 25 - 240/260	1	113757
XR - H 20 DN 25 - 280/300	1	113758
XR - H 20 DN 32 - 140/160	1	113761
XR - H 20 DN 32 - 180/220	1	113762
XR - H 20 DN 32 - 240/260	1	113763
XR - H 20 DN 32 - 280/300	1	113764
XR - H 20 DN 40 - 80/120	10	113765
XR - H 20 DN 40 - 140/160	1	113766
XR - H 20 DN 40 - 180/220	1	113767
XR - H 20 DN 40 - 240/260	1	113768
XR - H 20 DN 40 - 280/300	1	113769
XR - H 20 DN 50 - 80/120 *	10	113770
XR - H 20 DN 50 - 180/220	1	113772
XR - H 20 DN 50 - 240/260	1	113773
XR - H 20 DN 50 - 280/300	1	113774

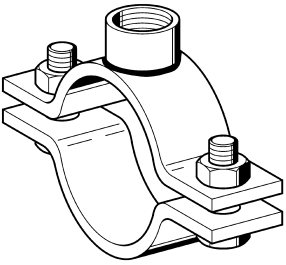

Produkt	Artikel	Pakirano	Artikel-št.
Trak iz steklenih vlaken GSK 	Skupina: 1291		
	30 x 2	10	114865
	40 x 2	10	114866
	50 x 2	10	114867
	60 x 2	10	114868
	70 x 2	10	114869
	80 x 2	10	800284
Barva za popravke ABL HT 	Skupina: A705		
	ABL HT	1	805515
Profilna guma SAL EPDM sk 	Skupina: 1294		
	30 x 1,0	20	188075
	40 x 1,0	20	188084
	50 x 1,0	20	188093
	60 x 1,0	20	188102
	70 x 1,0	20	188111
	80 x 1,0	20	800285
Objemka Stabil I-1/2" VA 	Skupina: 1719		
	22	25	188228
	27	25	188237
	34	25	188246
	44	25	188255
	49	25	188264
	61	25	188273
	77	25	188282
	89	25	188291
	115	10	188300

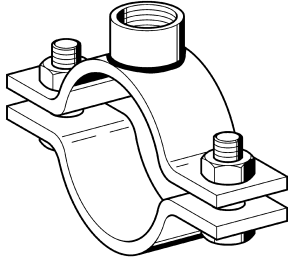
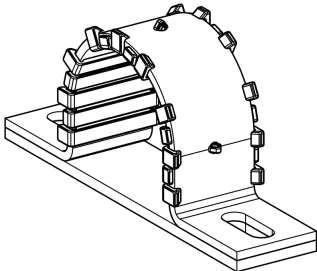

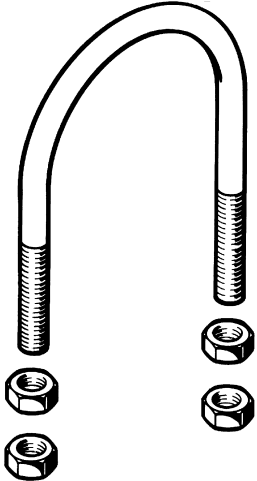
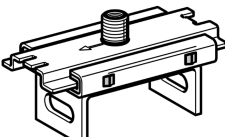
Produkt	Artikel	Pakirano	Artikel-št.
Objemka Stabil I-1/2" HCP 	Skupina: A022		
	22	25	188147
	27	25	188156
	34	25	188165
	44	25	188174
	49	25	188183
	61	25	188192
	77	25	188201
	89	25	188210
	115	10	188219
	Objemka RUC I 	Skupina: A023	
22		25	805068
28		25	805069
35		25	805070
43,5		25	805071
49,5		25	805072
62		25	805073
77,5		25	805074
90,5		25	805075
116		25	805076
141		10	805077
170		10	805078
221		10	805079
275		5	805080
325,5		1	805081



Produkt	Artikel	Pakirano	Artikel-št.
Streme navojno RUB DIN 3570 A HCP 	Skupina: 1810		
	26,9	50	162179
	33,7	50	162188
	42,4	50	162197
	48,3	50	162203
	60,3	50	162212
	76,1	50	162221
	88,9	50	162230
	114,3	25	162249
	139,7	25	162258
	168,3	10	162267
	193,7	10	162276
	219,1	10	162285
	273,0	10	162294
	323,9	1	162300
	355,6	1	162319
	406,4	1	162328
	508,0	1	162337
	Drsnik GS F 2G 	Skupina: A436	
GS F 80 2G		10	196700
GS F 80 2G2		10	196717
GS F 100 2G2		10	113093
Drsnik GS F 1G 	Skupina: A436		
	GS F 80 1G	10	113885
	GS F 80 1G2	10	113886
	GS F 100 1G	10	113091
	GS F 100 1G2	10	113092

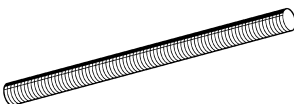
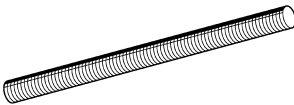
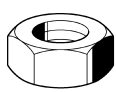
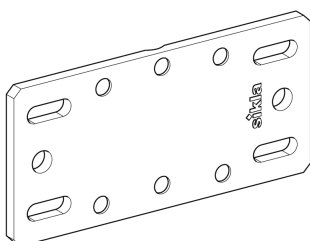

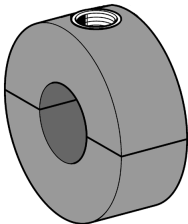

Produkt	Artikel	Pakirano	Artikel-št.	
Navojna palica GST HCP 	Skupina: 1817			
	M10	25	114842	
	M10	50	114112	
	M10	30	116569	
	M12	25	114843	
	M12	20	114113	
	M12	30	116570	
	M16	10	114844	
	M16	20	116572	
	M16	15	116571	
	Navojni zatič GST HCP 	Skupina: 1816		
		M10/40	100	162407
		M10/70	100	162416
M10/110		100	162425	
M12/70		100	162443	
M12/110		100	162452	
M12/200		100	162461	
M12/250		100	180686	
M12/300		100	180695	
M12/400		100	180713	
Matica šestroba NT HCP 	Skupina: 1871			
	M10	100	162391	
	M12	100	162382	
	M16	100	163019	
Adapter za ograjo GLA F 	Skupina: A441			
	GLA F 80	1	116812	
	GLA F 100	1	116815	

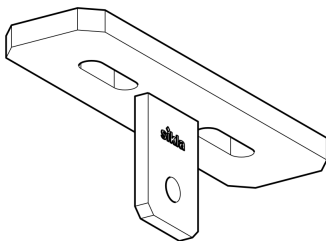
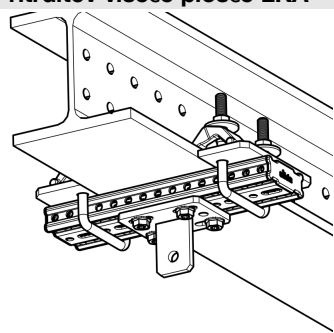

Produkt	Artikel	Pakirano	Artikel-št.	
Talna ploščica za hodnik FBT 	Skupina: A441			
	FBT	50	116816	
Objemka izolacijska RB 175 EX 	Skupina: 1253			
	12/30	1/2"/M10/M8	10	450302
	15/30 *	1/2"/M10/M8	10	117484
	16/30	1/2"/M10/M8	10	450301
	17/30 *	1/2"/M10/M8	10	193310
	18/30 *	1/2"/M10/M8	10	193327
	21/30	1/2"/M10/M8	10	168528
	22/30	1/2"/M10/M8	10	193334
	25/30	1/2"/M10/M8	10	450303
	27/30	1/2"/M10/M8	10	168537
	28/30	1/2"/M10/M8	10	193341
	33/30	1/2"/M10/M8	10	168546
	35/30	1/2"/M10/M8	10	193358
	42/30	1/2"/M10/M8	10	168555
	48/30	1/2"/M10/M8	10	168564
	50/30	1/2"/M10/M8	10	450300
	54/30	1/2"/M10/M8	10	193365
	57/30 *	1/2"/M10/M8	10	193372
	60/30	1/2"/M10/M8	10	168582
	64/30	1/2"/M10/M8	10	193389
	70/30	1/2"/M10/M8	10	193396
	76/30	1/2"/M10/M8	10	168607
	89/30	1/2"/M10/M8	5	168616
	108/40	1/2"/M10/M8	5	193402
	114/40	1/2"/M10/M8	5	193419
	125/40	1/2"/M10/M8	1	450304
	133/40	1/2"/M10/M8	5	193426
	139/40	1/2"/M10/M8	5	193433
	154/40	1/2"/M12	1	802189
	159/40	1/2"/M12	4	193440
168/40	1/2"/M12	4	193457	
180/60	3/4"/M16	1	450305	
200/60	3/4"/M16	1	450306	
204/60	3/4"/M16	1	193464	
219/60	3/4"/M16	1	193471	

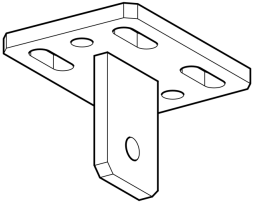
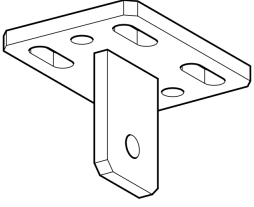
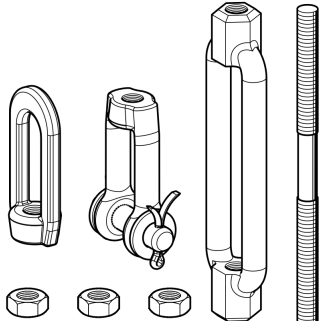
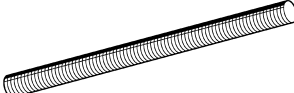
Produkt	Artikel	Pakirano	Artikel-št.
Plošča viseča HP 80/99 	Skupina: A299		
	HP 80/99 - A M10	10	113029
	HP 80/99 - A M12	10	113030
	HP 80/99 - A M16	10	113031
	HP 80/99 - B M12	10	113027
Pritrditev viseče plošče LKA 	Skupina: A299		
	LKA-A 100/160 M10	2	115833
	LKA-A 100/160 M12	2	115834
	LKA-A 100/160 M16	2	115835
	LKA-A 161/300 M10	2	115836
	LKA-A 161/300 M12	2	115837
	LKA-A 161/300 M16	2	115838
	LKA-B 100/160 M10	2	115826
	LKA-B 100/160 M12	2	115827
	LKA-B 100/160 M16	2	115828
	LKA-B 161/300 M10	2	115829
	LKA-B 161/300 M12	2	115831
	LKA-B 161/300 M16	2	115832
Adapter varilni HPA 	Skupina: A299		
	HPA M10-2	10	113017
	HPA M12-2	10	113018
	HPA M16-2	10	113019

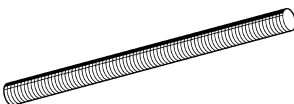
Produkt	Artikel	Pakirano	Artikel-št.	
Plošča viseča HP F 80 	Skupina: A299			
	HP F 80 - A M10	10	113023	
	HP F 80 - A M12	10	113024	
	HP F 80 - A M16	10	113025	
	HP F 80 - B M10	10	113020	
	HP F 80 - B M12	10	113021	
	HP F 80 - B M16	10	113022	
Plošča viseča HP F 100 	Skupina: A299			
	HP F 100 - A M10	10	115050	
	HP F 100 - A M16	10	115052	
	HP F 100 - B M10	10	115047	
	HP F 100 - B M12	10	115048	
	HP F 100 - B M16	10	115049	
Povezovalni set verige LKV 	Skupina: A299			
	LKV M10	10	113919	
	LKV M12	10	113920	
	LKV M16	10	113921	
Navojni zatič GST HCP 	Skupina: 1816			
	M10/40	100	162407	
	M10/70	100	162416	
	M10/110	100	162425	
	M12/70	100	162443	
	M12/110	100	162452	
	M12/200	100	162461	
	M12/250	100	180686	
	M12/300	100	180695	
	M12/400	100	180713	

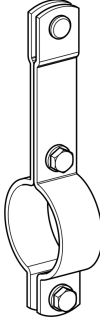
Produkt	Artikel	Pakirano	Artikel-št.	
Navojna palica GST HCP 	Skupina: 1817			
	M10	25	114842	
	M10	50	114112	
	M10	30	116569	
	M12	25	114843	
	M12	20	114113	
	M12	30	116570	
	M16	10	114844	
	M16	20	116572	
	M16	15	116571	
	Matica podaljšana AD IG/IG HCP 	Skupina: 1832		
M10 x 30		100	116700	
M12 x 35		50	116701	
M16 x 40		50	116702	
Objemka Stabil Form C LK 	Skupina: A299			
	22	25	113103	
	27	25	113104	
	34	25	113105	
	44	25	113106	
	49	25	113107	
	61	10	113108	
	77	10	113109	
	89	10	113110	
	115	10	113111	
	140	10	113112	
	169	1	113113	
	220	1	113114	
	273	1	113115	
	324	1	113116	

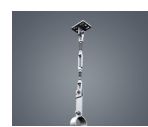

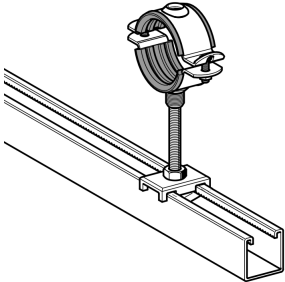
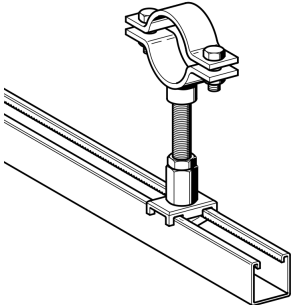
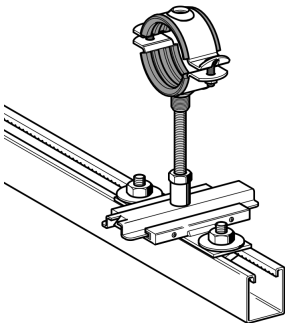
Produkt	Artikel	Pakirano	Artikel-št.
Sklop BG11 MS41-M10 	Skupina: 1102		
	DN 15	1	110144
	DN 20	1	110145
	DN 25	1	110146
	DN 32	1	110147
	DN 40	1	110148
	DN 50	1	110149
	DN 65	1	110150
	DN 80	1	110151
	DN 100	1	110152
Sklop BG11 MS41-1/2" 	Skupina: 1102		
	DN 15	1	110153
	DN 20	1	110154
	DN 25	1	110155
	DN 32	1	110156
	DN 40	1	110157
	DN 50	1	110158
	DN 65	1	110159
	DN 80	1	110160
	DN 100	1	110161
Sklop BG13 MS41-M10 	Skupina: 1102		
	DN 15	1	110180
	DN 20	1	110182
	DN 25	1	110183
	DN 32	1	110184
	DN 40	1	110185
	DN 50	1	110186
	DN 65	1	110187
	DN 80	1	110188
	DN 100	1	110189

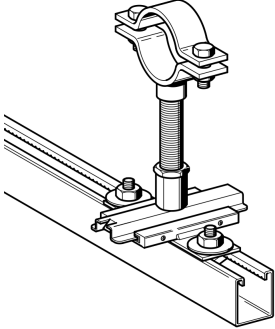
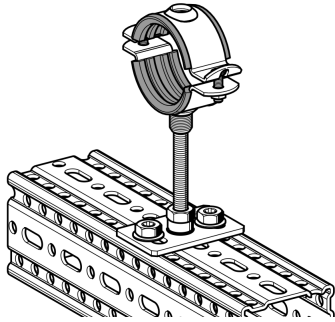
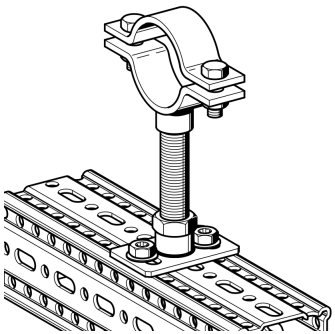
Produkt	Artikel	Pakirano	Artikel-št.
Sklop BG13 MS41-1/2"	Skupina: 1102		
	DN 15		110191
	DN 20	1	110192
	DN 25	1	110193
	DN 32	1	110194
	DN 40	1	110195
	DN 50	1	110196
	DN 65	1	110197
	DN 80	1	110198
	DN 100	1	110199
Sklop BG14 F80-M10	Skupina: 1102		
		1	803763
	DN 15	1	110200
	DN 20	1	110201
		1	803764
	DN 25	1	110202
	DN 32	1	110203
	DN 40	1	110204
		1	803765
	DN 50	1	110205
		1	803766
DN 65	1	110206	
	1	803767	
DN 80	1	110207	
	1	803768	
DN 100	1	110208	
Sklop BG14 F80-1/2"	Skupina: 1102		
	DN 15	1	110209
	DN 20	1	110210
	DN 25	1	110211
	DN 32	1	110212
	DN 40	1	110213
	DN 50	1	110214
	DN 65	1	110215
	DN 80	1	110216
	DN 100	1	110217

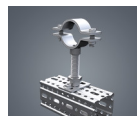

Produkt

Artikel

Pakirano

Artikel-št.

Sklop BG15 F80-M10

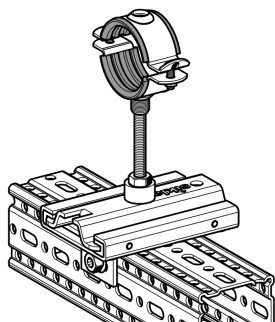

Skupina: 1102

DN 15	1	110218
DN 20	1	110219
DN 25	1	110220
DN 32	1	110221
DN 40	1	110222
DN 50	1	110223
DN 65	1	110224
DN 80	1	110225
DN 100	1	110226

Sklop BG15 F80-1/2"

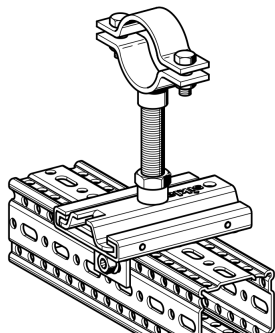

Skupina: 1102

DN 15	1	110227
DN 20	1	110228
DN 25	1	110229
DN 32	1	110230
DN 40	1	110231
DN 50	1	110232
DN 65	1	110233
DN 80	1	110234
DN 100	1	110235

Sklop BG16 F100-1/2"

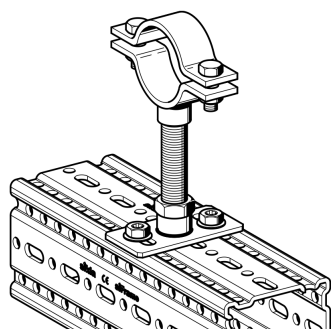

Skupina: 1102

DN 15	1	113842
DN 20	1	113843
DN 25	1	113844
DN 32	1	113845
DN 40	1	113846
DN 50	1	113847
DN 65	1	113848
DN 80	1	113849
DN 100	1	113850

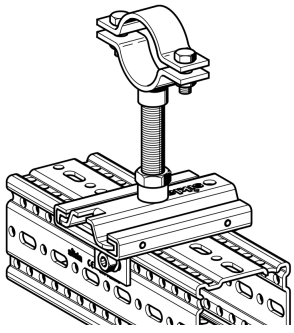
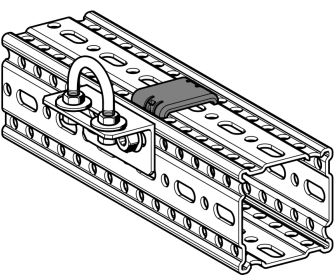
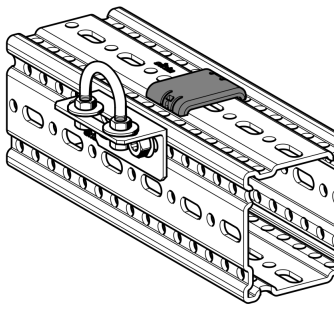
Produkt	Artikel	Pakirano	Artikel-št.
Sklop BG17 F100-1/2" 	Skupina: 1102		
	DN 15	1	113851
	DN 20	1	113852
	DN 25	1	113853
	DN 32	1	113854
	DN 40	1	113855
	DN 50	1	113856
	DN 65	1	113857
	DN 80	1	113858
	DN 100	1	113859
Sklop BG22 F80 	Skupina: 1102		
	DN 15	1	110236
	DN 20	1	110237
	DN 25	1	110238
	DN 32	1	110239
	DN 40	1	110240
	DN 50	1	110241
	DN 65	1	110242
	DN 80	1	110243
	DN 100	1	110244
	DN 125	1	110245
	DN 150	1	110246
Sklop BG22 F100 	Skupina: 1102		
	DN 15	1	113977
	DN 20	1	113978
	DN 25	1	113979
	DN 32	1	113980
	DN 40	1	113981
	DN 50	1	113982
	DN 65	1	113983
	DN 80	1	113984
	DN 100	1	113985
	DN 125	1	113986
	DN 150	1	113987
	DN 200	1	116919
	DN 250	1	116920
	DN 300	1	116921

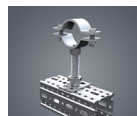

Produkt

Artikel

Pakirano

Artikel-št.

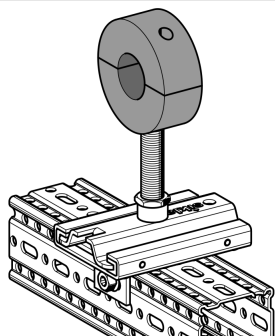
Sklop BG45 F80-1/2"**Skupina: 1102**

12/30	1	414308
15/30	1	414309
16/30	1	414311
17/30	1	414312
18/30	1	414313
21/30	1	110299
22/30	1	414314
25/30	1	414315
27/30	1	110300
28/30	1	414316
33/30	1	110301
35/30	1	414317
42/30	1	110302
48/30	1	110303
50/30	1	414318
54/30	1	414320
57/30	1	414321
60/30	1	110304
64/30	1	414322
70/30	1	414323
76/30	1	110305
89/30	1	110306
108/40	1	414325
114/40	1	110307

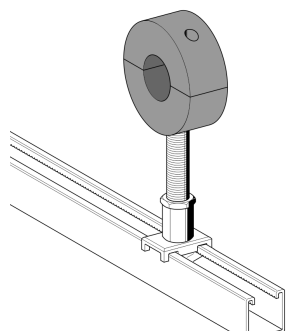
Sklop BG48 MS41-1/2"**Skupina: 1102**

12/30	1	414327
15/30	1	414329
16/30	1	414330
17/30	1	414331
18/30	1	414332
21/30	1	113904
22/30	1	414333
25/30	1	414334
27/30	1	113905
28/30	1	414335
33/30	1	113906
35/30	1	414336
42/30	1	113907
48/30	1	113908
50/30	1	414338
54/30	1	414339
57/30	1	414340
60/30	1	113909
64/30	1	414341
70/30	1	414342
76/30	1	113910
89/30	1	113911
108/40	1	414344
114/40	1	113912

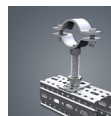

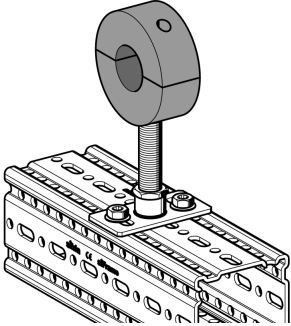
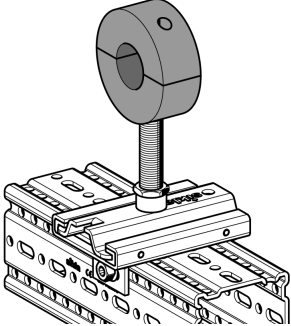
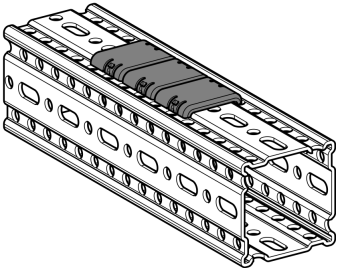
Produkt	Artikel	Pakirano	Artikel-št.
Sklop BG49 F100-1/2" 	Skupina: 1102		
	21/30	1	113860
	27/30	1	113861
	33/30	1	113862
	42/30	1	113863
	48/30	1	113864
	60/30	1	113865
	76/30	1	113866
	89/30	1	113867
	114/40	1	113868
Sklop BG50 F100-1/2" 	Skupina: 1102		
	21/30	1	113869
	27/30	1	113870
	33/30	1	113871
	42/30	1	113872
	48/30	1	113873
	60/30	1	113874
	76/30	1	113875
	89/30	1	113876
	114/40	1	113877
Sklop BG51 F80 	Skupina: 1102		
	F 80	1	112742

Produkt

Artikel

Pakirano

Artikel-št.

Sklop BG52 F80/100

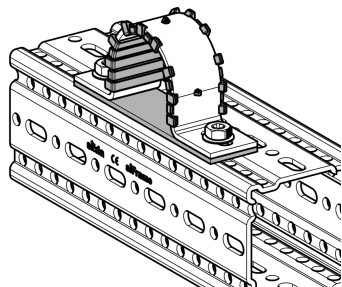

Skupina: 1102

22	1	114656
28	1	114657
35	1	114658
43	1	114659
49	1	114660
62	1	114661
77	1	114662
90	1	114663
116	1	114664
141	1	114665
170	1	114666
221	1	114667
275	1	114668
275	1	114669

Sklop BG54 F100

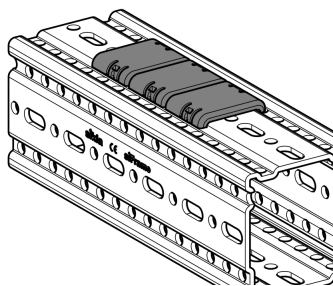

Skupina: 1102

F 100	1	113913
-------	---	--------

Sklop BG57 MS41

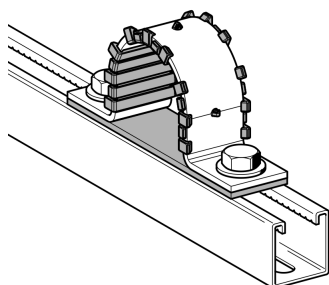

Skupina: 1102

22	1	114670
28	1	114671
35	1	114672
43	1	114673
49	1	114674
62	1	114675
77	1	114676
90	1	114677
116	1	114678

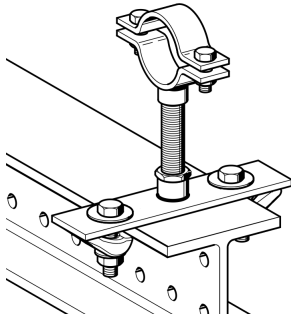
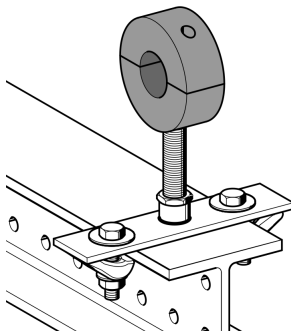
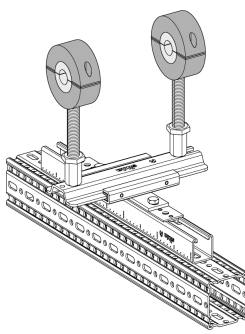

Produkt	Artikel	Pakirano	Artikel-št.
Sklop BG60 T100-1/2" 	Skupina: 1102		
	DN 15	1	112724
	DN 20	1	112725
	DN 25	1	112726
	DN 32	1	112727
	DN 40	1	112728
	DN 50	1	112729
	DN 65	1	112730
	DN 80	1	112731
	DN 100	1	112732
Sklop BG61 T100-1/2" 	Skupina: 1102		
	21/30	1	112733
	27/30	1	112734
	33/30	1	112735
	42/30	1	112736
	48/30	1	112737
	60/30	1	112738
	76/30	1	112739
	89/30	1	112740
	114/40	1	112741
Sklop BG82 F80/100-1/2" 	Skupina: 1102		
	64/40	1	414012
	70/40	1	414014
	76/40	1	414015
	85/50	1	414016
	89/50	1	414017
	102/50	1	414018
	104/40	1	414019
	108/40	1	414020
	114/50	1	414021

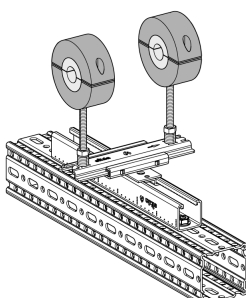
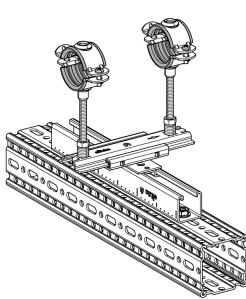
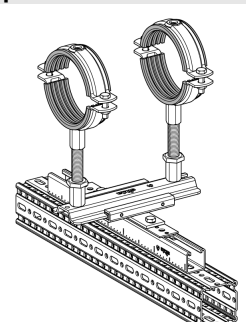
Produkt	Artikel	Pakirano	Artikel-št.
Sklop BG83 F80/100-M10 	Skupina: 1102		
	12/40	1	414023
	16/40	1	414024
	17/40	1	414025
	18/40	1	414026
	21/40	1	414027
	22/40	1	414028
	25/40	1	414029
	27/40	1	414030
	28/40	1	414032
	29/40	1	414033
	34/40	1	414034
	35/40	1	414035
	38/40	1	414036
	41/40	1	414037
	42/40	1	414038
	48/40	1	414039
	50/40	1	414041
	51/40	1	414042
	54/40	1	414043
57/40	1	414044	
60/40	1	414045	
Sklop BG84 F80/100-M10 	Skupina: 1102		
	DN15	1	416705
	DN20	1	416706
	DN25	1	416707
	DN32	1	416708
	DN40	1	416709
	DN50	1	416710
Sklop BG85 F80/100-1/2" 	Skupina: 1102		
	DN65	1	416714
	DN80	1	416715
	DN100	1	416716
	DN125	1	416717
	DN150	1	416718
	DN200	1	416719

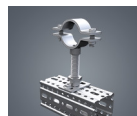

Produkt

Artikel

Pakirano

Artikel-št.

Sklop BG86 MS41-M10

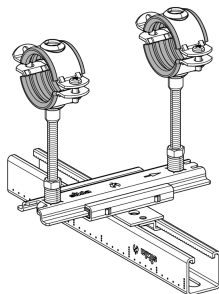

Skupina: 1102

DN15	1	416770
DN20	1	416771
DN25	1	416772
DN32	1	416773
DN40	1	416774
DN50	1	416775

Sklop BG87 MS41-1/2"

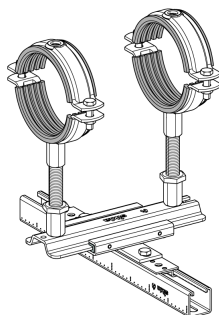

Skupina: 1102

DN65	1	416776
DN80	1	416777
DN100	1	416778
DN125	1	416779
DN150	1	416780
DN200	1	416781

Sklop BG88 MS41-1/2"

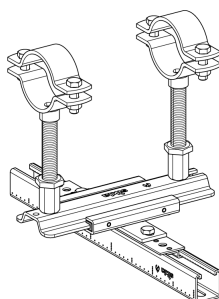

Skupina: 1102

DN15	1	414143
DN20	1	414144
DN25	1	414145
DN32	1	414146
DN40	1	414147
DN50	1	414149
DN65	1	414150
DN80	1	414151
DN100	1	414152

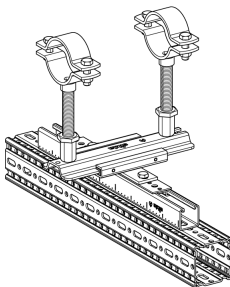
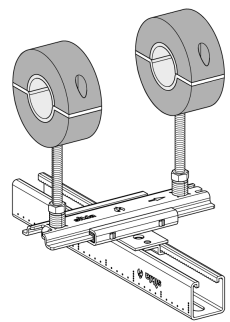
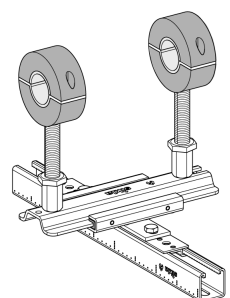
Produkt	Artikel	Pakirano	Artikel-št.
Sklop BG89 F80/100-1/2" 	Skupina: 1102		
	15	1	414133
	DN20	1	414134
	DN25	1	414135
	DN32	1	414136
	DN40	1	414137
	DN50	1	414138
	DN65	1	414140
	DN80	1	414141
	DN100	1	414142
Sklop BG90 MS41-M10 	Skupina: 1102		
	12/30	1	414114
	15/30	1	414115
	16/30	1	414116
	17/30	1	414117
	18/30	1	414118
	21/30	1	414119
	22/30	1	414120
	25/30	1	414122
	28/30	1	414123
	33/30	1	414124
	35/30	1	414125
	42/30	1	414126
	48/30	1	414127
50/30	1	414128	
54/30	1	414129	
57/30	1	414131	
60/30	1	414132	
Sklop BG91 MS41-1/2" 	Skupina: 1102		
	64/30	1	414107
	70/30	1	414108
	76/30	1	414109
	89/30	1	414110
	108/40	1	414111
	114/40	1	414113



Produkt

Artikel

Pakirano

Artikel-št.

Sklop BG92 F80/100-M10

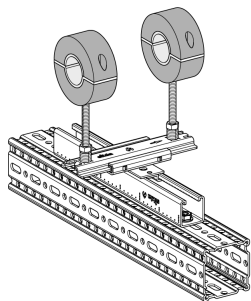

Skupina: 1102

12/30	1	414087
15/30	1	414088
16/30	1	414089
17/30	1	414090
18/30	1	414091
21/30	1	414092
22/30	1	414093
25/30	1	414095
27/30	1	414096
28/30	1	414097
33/30	1	414098
35/30	1	414099
42/30	1	414100
48/30	1	414101
50/30	1	414102
54/30	1	414104
57/30	1	414105
60/30	1	414106

Sklop BG93 F80/100-1/2"

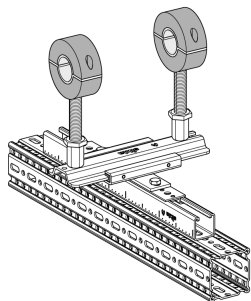

Skupina: 1102

64/30	1	414080
70/30	1	414081
76/30	1	414082
89/30	1	414083
108/40	1	414084
114/40	1	414086

ZERTIFIKAT ◆ CERTIFICATE ◆ 認証書 ◆ CERTIFICADO ◆ CERTIFICAT

MS01/10.05



Management Service

ZERTIFIKAT

Die Zertifizierungsstelle
der TÜV SÜD Management Service GmbH
bescheinigt, dass das Unternehmen

Sikla GmbH
In der Lache 17, D-78056 Villingen-Schwenningen
Schillerstraße 5, D-78595 Hausen
Spannstiftstraße 37, D-58119 Hagen
Sikla Austria Ges. m.b.H.,
Kornstraße 4, A-4610 Marchtrenk

für den Geltungsbereich

**Entwicklung und Vermarktung von Systemen zur
Befestigung und Verbindung von Rohren, zur
Dachentwässerung und Vorwandtechnik in der
technischen Gebäudeausrüstung und im Anlagenbau**

ein Qualitätsmanagementsystem
eingeführt hat und anwendet.

Durch ein Audit, Bericht-Nr. **70019146**
wurde der Nachweis erbracht, dass die Forderungen der

ISO 9001: 2000

erfüllt sind. Dieses Zertifikat ist gültig bis **2009-09-24**

Zertifikat-Registrier-Nr. **12 100 3158 TMS**



M. Norgel

München, 2006-09-26



QMS-TGA-ZM-07-92

1. Splošno: Sledeči pogoji so edini merodajni pogoji za celotno poslovanje, tudi takrat, kadar je naročnik uradno določil drugačne pogoje. Veljajo za sprejete s strani kupca, v kolikor kupec pri naročilu ni ugovarjal. Telefonska ali ustna dopolnila oz. spremembe potrebujejo za veljavnost naše pisno potrditev. Vsi dosedanji prodajni pogoji so s tem neveljavni.

2. Naše ponudbe so, če ni drugačnega dogovora, neobvezne. Za slike in risbe v naših katalogih, kakor tudi pri naših vzorcih si pridržujemo lastniško in avtorsko pravico. Brez našega dovoljenja ne smejo biti dostopne tretjim osebam in jih je potrebno na zahtevo nemudoma vrniti. Mere in tehnični podatki: Vse navedena mere in tehnični podatki imajo približne vrednosti. Za upoštevanje ne prevzemamo nobene odgovornosti. Pridržujemo si pravico do sprememb.

3. Cene v EUR veljajo franko podjetje oz. podružnica brez embalaže in z dodanim DDV. Obračunajo se cene, veljavne na dan dobave. Pridržujemo si pravico do spremembe cen.

4. Dobava: Navedeni dobavni roki pričnejo veljati z dnem potrditve naročila in so neobvezujoči. Reklamacije, ki so nastale zaradi zavlačevanja dobavnih rokov, ki so nastali zaradi motenj v podjetju, nepredvidenih težav pri dobavi surovin in obratnih sredstev oz. zaradi višje sile, se ne priznajo. Izključuje se možnost odstopa od dobave. Delne dobave so dopustne na stroške naročnika. Pri napisnih tablah za gradbišča in samolepilnih folijah lahko pride do preseganja naročne količine za 10 % Ker gre za izdelavo po posebnem naročilu, mora naročnik prevzeti in plačati presežek.

5. Sukcesivne dobave, v kolikor to ni v potrdilu naročila drugače določeno, morajo biti prevzete v roku štirih mesecev po zaključku naročila, ne da bi z naše strani prišla zahteva za prevzem. V kolikor je ta rok prekoračen, si pridržujemo pravico blago zaračunati ali stornirati naročilo.

6. Odprema se vedno izvrši na račun in riziko naročnika. Kadar se ne navedejo odpremi pogoji, se vedno izbere najugodnejša transportna pot, brez odgovornosti za najcenejše pošiljanje ali dospelje blaga v dobrem stanju. Razlika je le pri odpremi blaga v vrednosti najmanj EUR 300,-- , kjer velja pariteta fco sprejemna postaja.

7. Embalaža se zaračuna po lastni nabavni ceni. Vsa uporabljena embalažna sredstva, kot so lepenka, zaboji za enkratno uporabo iz vezanih plošč ali običajni leseni zaboji so nepovratna.

8. Plačilo: Naši računi so plačljivi v roku 30 dni od dneva izstavitve računa neto (ne po datumu prejema računa ali blaga). Pri plačilu v roku 10 dni od dneva izstavitve računa priznamo 3 % skonto na vrednost računa, pod pogojem, da so vse zapadle fakture poravnane. Plačilni rok je izpolnjen, če je nakazilo ali s čekom plačan znesek v roku knjižen v dobro na enem naših bančnih računov.

Menic, kot plačilnega sredstva, ne sprejemamo. Pri mednarodnih plačilih grede bančni stroški za izvršitev nakazila doma na naš račun in stroški v tujini na račun zavezanca za plačilo. Večkratni skonto odbitki oz. skonto odbitki po roku plačila, kot tudi zmanjšanje stroškov pošiljanja in embalaže, se ne priznavajo.

Pri zamudi rokov plačil se zaračunavajo običajne bančne zamudne obresti. V kolikor zapadli računi kljub opominu niso poravnani, zapadejo v plačilo vsi odprti računi. Razen tega si pridržujemo pravico do popolne ali delne ukinitve količinskega popusta.

Nepoznanim kupcem lahko v začetku dobavljamo blago le proti predplačilu. Smatra se za dogovorjeno, da nosi stroške pri zamudi plačila ali izvensodne inkaso stroške in stroške opominov s strani odvetnika, naročnik blaga.

9. Zgoraj omenjeni dobavni in plačilni pogoji veljajo v primeru vašega naročila, kot sporazumno dogovorjeni, tudi če so vaši pogoji ob naročilu drugačni. Razveljavijo se lahko delno ali v celoti le, če se pisмено sporazumemo drugače.

10. Pridržanje pravice do lastništva: Dobavljeno blago ostaja naša last do popolnega plačila oz. do vnovčitve čeka, tudi pri ponovni prodaji. Zastava ali dajanje v varščino nista dovoljena. Kupec nas je dolžan nemudoma obvestiti o pričakovani ali izvršeni izvržbi oz. ob vsakem kratenju naših pravic s strani tretje osebe. Po stečajnem pravilniku imamo pravico na izločitev oz. odstop naše pravice na poplačilo. V primeru prevzema z naše strani dobavljenega blaga s pridržano lastninsko pravico, s strani tretje osebe, nas mora naročnik o tem nemudoma obvestiti. Morebitni stroški za potrebno intervencijo napram tretji osebi grede v breme naročnika.

11. Reklamacije glede kakovosti pošiljke je potrebno sporočiti najpozneje v roku 5 dni po prejemu pošiljke. V nasprotnem primeru se smatra pošiljka kot sprejeta. Naša obveza se omejuje na naknadno dobavo blaga ali dobropis za blago. Za izdelke tujih proizvajalcev jamčimo načelno le v obsegu, za katerega jamčijo in prevzemajo obveznosti tudi naši poddobavitelji. Morebitno vračilo pošiljke brez predhodnega dogovora s prodajalcem ni dovoljeno. V kolikor gre pri tem za delne pošiljke, se obravnavano naročilo iz tega razloga ne more anulirati.

12. Garancija oz. garancijski rok: garancijski rok znaša na čeloma 24 mesecev od dneva nakupa za brezhibno kvaliteto blaga, izvedbo in delovanje pod pogoji, da prvič blago pred predelavo oz. uporabo ni bilo izpostavljeno škodljivim vplivom in drugič, da je bila predelava ali montaža izvedena primerno stanju tehnike.

13. Vračilo blaga: Načeloma se ne sprejme pravilno dobavljeno in prodano blago. Izjeme so možne samo v določenih, dogovorjenih primerih. V kolikor smo zaradi kulantnosti pripravljene sprejeti vrnjeno blago, se odbije naročniku 10 % stroškov za ponovno skladiščenje blaga.

Pošiljka mora biti vrnjena brez stroškov. Blago mora biti dobro zapakirano. Dodelave, ki bi bile potrebne zaradi slabega pakiranja ali drugih vplivov, se zaračunajo po lastni ceni. Pri posebnih izdelavah, ki jih ni mogoče prodati naprej, je vračilo blaga izključeno.

14. Kraj izpolnitve za vse posle, kakor tudi za vse ostale pravice in obveznosti, ki izhajajo iz posla so Crenšovci. Pristojno sodišče je v Murski Soboti.