

## Izdaja 2026

### Uprava in centralno skladišče

Sikla d.o.o.

Prekmurske čete 99

9232 Črenšovci

Telefon +386 (0)2 573 58 62

E-mail: [info.si@sikla.com](mailto:info.si@sikla.com)

Internet: [www.sikla.si](http://www.sikla.si)



## Vsebina

---

### 1 Cevne objemke in pribor

---

### 2 Pritrditev zračnih kanalov

---

### 3 Montažni profili in pribor

---

### 4 Konzole, osnovne plošče in montažni kotniki

---

### 5 Drsniki

---

### 6 Pritrditev za nosilce in trapezno pločevino

---

### 7 Zvočno izolacijski elementi

---

### 8 Vijaki, sidra in pribor

---

### 9 Fiksne točke

---

### 10 Montažni sistem Pressix CC 27

---

### 11 Tablice

---

### 12 Izolacija

---

### 13 Nerjaveče jeklo

---

### 14 HCP – zaščita materiala

---

### 15 Montažni sistem siMetrix 46

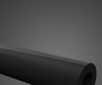
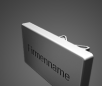
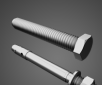
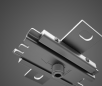
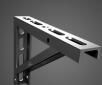
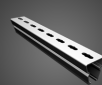

<b>A</b>			
Adapter AD IG/IG	23	Element gumijasti koviski GMT	58
Adapter AD IG/IG HCP	124	Eurobatex AT Solar	101
Adapter AD IG/IG VA	109	Eurobatex ETX C1 19 - 40 mm	99
Adapter montažni profil 27/41 na PRO 46	139	Eurobatex ETX C1 6 - 13 mm	98
Adapter montažni profil 80/100 na PRO 46	139	<b>F</b>	
Adapter PK 46	140	Flis za nosilce podstavkov SHB VL	93
Adapter za fiksno točko FPA	47	<b>G</b>	
Adapterska plošča AP 46	140	Guma Silentplus Rubber SPR	102
Akustični element AKE	58	<b>I</b>	
<b>B</b>		Izolacija v roli Eurobatex ETX C1	101
Blok PB 27	84	Izolacija v roli Eurobatex ETX C1 SK	101
Blok PB 41	35	Izolacijska cev Climaflex CFX protect	92
Blok PBH 41	34	Izolacijska cev Climaflex CFX silence	92
Blok PBH 46	142	Izolacijska cev ISOST LX	93
Bočna ojačitev CFB 46	143	Izolacijska plošča Eurobatex C1	100
Bočna ojačitev CFB HCP	128	Izolacijska plošča Kelon	95
<b>C</b>		Izolacijski trak Anker	103
Centrirni sveder ZB	55	Izolacijski trak CFX	97
Cevak ISA	103	Izolacijski trak Climaflex CFX PE	92
Cevna zanka RSL N	23	Izolacijski trak Eurobatex	100
Cink sprej ZS HCP	137	Izolacijski trak ISOST LX	93
Climaflex CFX Basic Stabil	96	<b>J</b>	
Climaflex CFX Natur	94	Jeklena vrv SDS	30
Climaflex CFX Natur Easy	95	<b>K</b>	
Climaflex CFX Natur Easy koleno	95	Karabin KBR	32
Climaflex CFX Natur Easy T-kos	96	Kit silikonski SIK	80
Climaflex CFX Natur Stabil	96	Klema za jekleno vrv DSL	31
<b>D</b>		Klema za objemke MPK 46	141
Del cevni vpenjali SCB	64	Klešče montažne za ANC-M MZ	71
Distančnik HRS P	41	Klešče za luknjanje LOT	55
Drсна podloga GA 41-46	143	Klešče za PNS navojni zatič PBC	69
Dršnik GS 1G	48	Kljuka navojna GH	53
Dršnik GS 2G	48	Kljuka vpenjalna SP	53
Dršnik GS 2G VA	115	Kljuka-S SHK	31
Dršnik GS 2G-PL	49	Konzola kotna WK	44
Dršnik GS 2G-PL HCP	133	Konzola kotna WK CC	44
Dršnik GS 2G-PL VA	115	Konzola kotna WK HCP	129
Dršnik GS 41	50	Konzola kotna WK VA	114
Dršnik GS 41 VA	116	Konzola objemna SKL	51
Dršnik GS CC - 2G-PL	49	Konzola oporna ST	45
Dršnik GS CC - H3G-PL	50	Konzola previsna AK	45
Dršnik GS H3G	49	Konzola previsna AK 27 - 1,25	86
Dršnik GS H3G VA	115	Konzola previsna AK 46-P	138
Dršnik GS H3G-PL	49	Konzola previsna AK CC	45
Dršnik GS H3G-PL 46	141	Konzola previsna AK CC 46-P	138
Dršnik GS H3G-PL VA	116	Konzola previsna AK HCP	131
Držalo - WBD	42	Konzola previsna AK VA	114
Držalo MOF 27	86	Kos prehodni AD IG/AG	67
Držalo profila SH	38	Kos prehodni AD IG/AG VA	118
Držalo profila SH HCP	128	Kotni spojnik EV CC 41-1	40
Držalo WBD 46	139	Kotni spojnik EV CC 41-1 HCP	129
Držalo WBD HCP	130	Kotni spojnik EV CC 41-2	40
Držalo WBD VA	112	Kotni spojnik EV CC 41-2 HCP	129
Držalo WBD-C HCP	131	Kotni spojnik EV CC 41-3	40
<b>E</b>		Kotni spojnik EV CC 41-3 HCP	130
Element drsni GLE J	48	Kotni spojnik EV CC 41-4	40
Element drsni GLE LC	48	Kotni spojnik EV CC 41-4 HCP	130

Kotni spojnik EV CC 41-5	41	Montažni komplet SCAD	34
Kotni spojnik EV CC 41-5 HCP	130	Montažni profil MS	33
Kotni spojnik EW 41-1	39	Montažni profil MS 27 – 1,25	84
Kotni spojnik EW 41-1 HCP	129	Montažni profil MS 41 HCP	126
Kotnik CN CC 27-90°	85	Montažni profil MS VA	110
Kotnik CN CC 41 Stabil	43	Montažni profil PRO 46	138
Kotnik CN CC 41-90°	43	Montažno držalo profila MPH 46	139
Kotnik kanalni LUW	28	Mufa očesna SCB VA	117
Kotnik kanalni LUW A	28		
Kotnik kanalni LUW F	28	<b>N</b>	
Kotnik kanalni LUW HCP	126	Napenjalo SPSL	32
Kotnik montažni MW 90° W Stabil VA	113	Nastavek BIT Torx 30	75
Kotnik montažni MW HCP	128	Nastavek magnetni MN	64
Kotnik montažni MW LL	43	Nastavek za vijak hanger ANT BIT	61
Kotnik montažni MW S	43	Nastavek za žago luknjarico ZBT	54
Kotnik montažni MW S HCP	128	Navojna cev GR	70
Kotnik montažni MW VA	113	Navojna cev GR HCP	136
Kotnik vezni FLW	29	Navojna cev GR VA	119
Križni drsnik KGL 46	143	Navojna palica BSK 5.8	70
		Navojna palica GST 4.8	70
<b>L</b>		Navojna palica GST HCP	136
Laserska obdelava	90	Navojna palica GST VA	119
Lepilni trak Alltape	103	Navojni zatič GST	68
Lepilni trak Coroplast 910 Alu-SE	104	Navojni zatič GST 8.8	69
Lepilni trak Coroplast 918 Alu	104	Navojni zatič GST HCP	136
Lepilni trak GKB	104	Navojni zatič PNS	69
Lepilni trak Sikla-Plast	104	Navojno držalo GWB HCP	134
Lepilo CFX NMC-fix	97		
Lepilo Eurobatex AT N	102	<b>O</b>	
Lepilo Eurobatex ETX CNX	100	Obešalo trapezno TRH	55
Luknjalo LS LOT	56	Objemka drsna Ratio S-K	3
		Objemka drsna Stabil D-3G-K	14
<b>M</b>		Objemka ERS ME	1
Masa za sidranje POLY SF	73	Objemka fikse točke FS	81
Masa za sidranje VME plus	63	Objemka hladilna KF 170 EX	21
Masa za sidranje VMH	63	Objemka hladilna KF 175 CoolHot	22
Masa za sidranje VMU plus	73	Objemka hladilna LKS 13	16
Masa za sidranje VMZ	73	Objemka hladilna LKS 19	17
Matica kljukasta NT CC 27	84	Objemka hladilna LKS 32	18
Matica kljukasta NT CC 41	35	Objemka hladilna RB 175 EX	20
Matica kljukasta NT CC 41 HCP	126	Objemka hladilna SKS Top-2C	19
Matica kljukasta NT CC 41 VA	110	Objemka hladilna za fiksno točko FKS	82
Matica kljukasta NT HZ 41	35	Objemka LRS	11
Matica kljukasta NT HZ 41 HCP	126	Objemka Ratio 3G	3
Matica kljukasta NT HZ 41 VA	111	Objemka Ratio LS	1
Matica narebričena N	67	Objemka Ratio LS Silikon	2
Matica navojna NT	36	Objemka Ratio S	2
Matica navojna NT 27	85	Objemka Ratio S M8	1
Matica navojna NT VA	111	Objemka Stabil B VA	109
Matica podaljšana AD IG/IG HCP	136	Objemka Stabil B-M12 VA	108
Matica prirobna NT FLA	66	Objemka Stabil D - VA	106
Matica prirobna NT SEC HCP	135	Objemka Stabil D-1/2" brez obloge	4
Matica šestroba NT	66	Objemka Stabil D-1/2" z oblogo	5
Matica šestroba NT HCP	135	Objemka Stabil D-1G VA	107
Matica šestroba NT VA	118	Objemka Stabil D-1G VA Silikon	108
Matica zaključna NT 3G	7	Objemka Stabil D-1G VA z oblogo	107
Montažni komplet MOS	38	Objemka Stabil D-2G/-3G Silikon VA	114
Montažni komplet MOS 27	86	Objemka Stabil D-2G/-3G VA	111
Montažni komplet MOS CC	38	Objemka Stabil D-2G/-3G z oblogo VA	113
Montažni komplet PBS 46	142	Objemka Stabil D-3G	6
Montažni komplet PBS CC 27	84	Objemka Stabil D-3G HCP	122
Montažni komplet PBS CC 41	34	Objemka Stabil D-3G Silikon	9

Objemka Stabil D-3G z oblogo	8	Profilni žebelj PN 27	80
Objemka Stabil D-3G z oblogo HCP	123	Protimatica NT G	70
Objemka Stabil D-A	10	Protimatica NT G HCP	137
Objemka Stabil D-M16	11		
Objemka Stabil D-M16 Silikon	13	<b>R</b>	
Objemka Stabil D-M16 z oblogo	12	Razcepnik /Sveder za sidra ASW	79
Objemka Stabil RB-A	15	Redukcija navojna AD AG/IG	68
Objemka Stabil RB-A HCP	124		
Objemka vijačna SRS 2G brez obloge	4	<b>S</b>	
Objemka vijačna SRS VA	105	Set konzole KIT A	46
Objemka vijačna SRS VA z oblogo	106	Set konzole KIT B	46
Objemka zračna brez obloge od DN 560	26	Sidro AN BZ plus	77
Objemka zračna PLU 2G z oblogo	25	Sidro AN BZ plus A4	120
Objemka zračna PLU TOP 2G z oblogo	25	Sidro AN BZ3	78
Objemka zračna Stabil D BSK	27	Sidro AN BZ3 A4	120
Objemka zračna z oblogo od DN 560	26	Sidro udarno AN	76
Opornik STR	44	Sidro udarno AN ES	79
Opornik STR VA	112	Sidro za votle strope AN Easy	80
Orodje za nameščanje sidro BWS	79	Sklop fiksne točke FPK	81
Osnovna plošča GPL	46	Sklop povezovalni VP A/B	82
Osnovna plošča GPL F 80 Stabil	46	Sklop povezovalni VP SDE 2	83
Osnovna plošča GPL HCP	131	Sklop za profil SK	37
Osnovna plošča GPL Siaqua	47	Sklop za profil SK HCP	127
Osnovna plošča GPL VA	115	Sklop za profil SK-L HCP	127
Ozobje kljukasto HK	37	Spojka Climaflex CFX	97
Ozobje kljukasto HK 27	87	Spojnik CN 46	138
Ozobje kljukasto HK BL	37	Spojnik dvojni navojni BOL M8	61
Ozobje kljukasto HK HCP	127	Spona za nosilec TCS	51
Ozobje kljukasto HK VA	112	Spona za nosilec TCS 41	51
		Spona za nosilec TCS 41 HCP	133
<b>P</b>		Spona za nosilec TCS F (VdS/FM)	51
Plastično votla pritrditev ANC-K M4/12	72	Spona za nosilec TCS HCP	132
Plošča kotna ECO CC	39	Spona za nosilec TCS VA	116
Plošča pritrjevalna FPKNO	81	Spona za ventilacijske cevi LUB	27
Plošča ravna FPFL-ST	81	Streme navojno RUB	24
Plošča varovalna SL VdS	52	Streme navojno RUB 46	141
Ploščica dvojna držalna DHP M8	61	Streme navojno RUB DIN 3570 A HCP	125
Podaljšek navojni AD IG/IG	67	Streme navojno RUB VA	110
Podaljšek navojni AD IG/IG VA	118	Streme vpenjalno SB 27	86
Podaljšek okrogli AD RD	67	Streme vpenjalno SB 41	54
Podložka US	66	Streme vpenjalno SB 41 HCP	133
Podložka US HCP	135	Streme vpenjalno SB 46	140
Podložka US VA	118	Svod raziralni za udarna sidra ANT MSH	80
Podnožje SHB HCP	131		
Podnožje SHB SQF 41	42	<b>T</b>	
Podnožje SHB SQF 46	140	Tablica barvna LOG	89
Podnožje SHB SQF-41L	42	Tablica brez vpenjanega traka UNI	88
Pokrov plastični SHA	89	Tablica privarilna UNI	88
Pokrov za profile MSA	34	Tablica privijalna SHT	88
Prazna letev SLL	90	Tablica z vpenjalnim trakom UNI M S	88
Pribor VMZ / VMU plus	73	Tesnilna masa DP 30/45	82
Priključni kos ASS M16	35	Tesnilna masa DP S-1035	82
Pritrditev za streme UBF HCP	125	Trak iz steklenih vlaken GSK	60
Profilna guma SAL	30	Trak ježek KBD	89
Profilna guma SAL 27	87	Trak perforiran pocinkan - BND	29
Profilna guma SAL 46	143	Trak perforiran PVC - BND	29
Profilna guma SAL EPDM sk	59	Trak samolepilni iz penaste gume MSK	59
Profilna guma SAL SBR/EPDM	58	Trak vpenjalni LOH ALU	89
Profilna guma SAL Silikon	59	Tulec sitasti PVC VMU - SH	74
Profilna guma SAL Silikon sk	59		
Profilna guma SAL SK	30	<b>U</b>	
Profilni teleskop ST 41	42	Udarno sidro AN VA	121

## V

Veriga GLK	30
Vežni element za montažne profile KL	37
Vijačno sidro TFF en kos	76
Vijačno sidro TSM LP VZ 30	75
Vijačno sidro TSM-IM	76
Vijačno sidro TSM-S	75
Vijačno sidro TSM-ST	74
Vijak hanger brez vezi BSCR	61
Vijak hanger brez vezi BSCR VA	117
Vijak lesni FLAH	62
Vijak matični za trapez MSR	55
Vijak očesni SCR	63
Vijak ploščični SCR	63
Vijak s kljukasto glavo HM 27	85
Vijak s kljukasto glavo TBO HZ 41	36
Vijak s kljukasto glavo TBO HZ 41 HCP	127
Vijak s kljukasto glavo TBO HZ 41 VA	112
Vijak s prirobnico SCR FLA HCP	135
Vijak samorezni SCR L	64
Vijak šestrobe lesni SKH VA	117
Vijak šestrobi lesni SKH	62
Vijak šestrobi SKT	65
Vijak šestrobi SKT HCP	134
Vijak šestrobi SKT VA	117
Vijak sidrni VMU-A	74
Vijak sidrni VMZ-A	74
Vijak sidrni VMZ-A A4	119
Vijak SNK TG	62
Vijak z vgrezno glavo SCR	7
Vijak z vrtno konico SKB	64
Vložek iz medenine ANM	72
Vložek obračalni KD	54
Vložek previsni ANC-MK	72
Vložek TBD m.S.	72
Vložek z žabljem ANH	71
Vložek za votle stene ANC-M	71
Vložek zidni ANA	71

Vozliščna plošča KNO	39
Vpenjalni komplet SPZ HCP	134
Vpenjalni nastavek P	53
Vpenjalni nastavek SPA 5P AU HCP	134
Vpenjalni nastavek SPA 5P HCP	133
Vpenjalni nastavek SPA 5P VA	105
Vtisk	90

## Z

Zaključna kapica ADK	33
Zaključna kapica ADK 27	85
Zaključna kapica ADK 46	142
Zaključna kapica ADK WK	44
Zanka za jekleno vrv DSK	31
Zglob JOI 41 HCP	132
Zglob JOI 41 T HCP	132
Zglob JOI R	53
Zglob JOI S	52
Zglob SG	52
Zglob univerzalni UG	52
Zglob univerzalni UG VA	116
Zvočni dušilec SDE 0	57
Zvočni dušilec SDE 1	57
Zvočni dušilec SDE 2 - FP 1	58
Zvočni dušilec SDE 2 - UG 16	57
Zvočni dušilec SDE 2 - SBV/SBZ	57
Zvočni dušilec SDE 27	87
Zvočno izolacijski element SDE	29

## Č

Čistilo za lepljenje izolacije	102
Člen za spajanje verige SGL	31

## Ž

Žabica LCO 20/30/40	27
Žabica LCO 30/40	28
Žaga luknjarica LS	54

<b>1 Cevne objemke in pribor</b>	<b>1</b>	<b>3 Montažni profili in pribor</b>	<b>33</b>
Objemka ERS ME	1	Montažni profil MS	33
Objemka Ratio S M8	1	Zaključna kapica ADK	33
Objemka Ratio LS	1	Pokrov za profile MSA	34
Objemka Ratio LS Silikon	2	Montažni komplet PBS CC 41	34
Objemka Ratio S	2	Montažni komplet SCAD	34
Objemka drsna Ratio S-K	3	Blok PBH 41	34
Objemka Ratio 3G	3	Blok PB 41	35
Objemka vijačna SRS 2G brez obloge	4	Priključni kos ASS M16	35
Objemka Stabil D-1/2" brez obloge	4	Matica kljukasta NT CC 41	35
Objemka Stabil D-1/2" z oblogo	5	Matica kljukasta NT HZ 41	35
Objemka Stabil D-3G	6	Matica navojna NT	36
Vijak z vgrezno glavo SCR	7	Vijak s kljukasto glavo TBO HZ 41	36
Matica zaključna NT 3G	7	Vežni element za montažne profile KL	37
Objemka Stabil D-3G z oblogo	8	Ozobje kljukasto HK	37
Objemka Stabil D-3G Silikon	9	Ozobje kljukasto HK BL	37
Objemka Stabil D-A	10	Sklop za profil SK	37
Objemka Stabil D-M16	11	Držalo profila SH	38
Objemka LRS	11	Montažni komplet MOS	38
Objemka Stabil D-M16 z oblogo	12	Montažni komplet MOS CC	38
Objemka Stabil D-M16 Silikon	13	Vozliščna plošča KNO	39
Objemka drsna Stabil D-3G-K	14	Plošča kotna ECO CC	39
Objemka Stabil RB-A	15	Kotni spojnik EW 41-1	39
Objemka hladilna LKS 13	16	Kotni spojnik EV CC 41-1	40
Objemka hladilna LKS 19	17	Kotni spojnik EV CC 41-2	40
Objemka hladilna LKS 32	18	Kotni spojnik EV CC 41-3	40
Objemka hladilna SKS Top-2C	19	Kotni spojnik EV CC 41-4	40
Objemka hladilna RB 175 EX	20	Kotni spojnik EV CC 41-5	41
Objemka hladilna KF 170 EX	21	Distančnik HRS P	41
Objemka hladilna KF 175 CoolHot	22		
Adapter AD IG/IG	23	<b>4 Konzole, osnovne plošče in montažni</b>	
Cevna zanka RSL N	23	<b>kotniki</b>	<b>42</b>
Streme navojno RUB	24	Držalo - WBD	42
		Podnožje SHB SQF 41	42
<b>2 Pritrditev zračnih kanalov</b>	<b>25</b>	Podnožje SHB SQF-41L	42
Objemka zračna PLU TOP 2G z oblogo	25	Profilni teleskop ST 41	42
Objemka zračna PLU 2G z oblogo	25	Kotnik CN CC 41-90°	43
Objemka zračna brez obloge od DN 560	26	Kotnik CN CC 41 Stabil	43
Objemka zračna z oblogo od DN 560	26	Kotnik montažni MW S	43
Objemka zračna Stabil D BSK	27	Kotnik montažni MW LL	43
Spona za ventilacijske cevi LUB	27	Konzola kotna WK	44
Žabica LCO 20/30/40	27	Konzola kotna WK CC	44
Žabica LCO 30/40	28	Zaključna kapica ADK WK	44
Kotnik kanalni LUW	28	Opornik STR	44
Kotnik kanalni LUW A	28	Konzola oporna ST	45
Kotnik kanalni LUW F	28	Konzola previsna AK	45
Kotnik vezni FLW	29	Konzola previsna AK CC	45
Trak perforiran pocinkan - BND	29	Set konzole KIT A	46
Trak perforiran PVC - BND	29	Set konzole KIT B	46
Zvočno izolacijski element SDE	29	Osnovna plošča GPL	46
Profilna guma SAL	30	Osnovna plošča GPL F 80 Stabil	46
Profilna guma SAL SK	30	Osnovna plošča GPL Siaqua	47
Veriga GLK	30	Adapter za fiksno točko FPA	47
Jeklena vrv SDS	30		
Zanka za jekleno vrv DSK	31	<b>5 Drsniki</b>	<b>48</b>
Klema za jekleno vrv DSL	31	Element drsni GLE LC	48
Člen za spajanje verige SGL	31	Element drsni GLE J	48
Kljuka-S SHK	31	Drsnik GS 1G	48
Karabin KBR	32	Drsnik GS 2G	48
Napenjalo SPSL	32	Drsnik GS 2G-PL	49
		Drsnik GS CC - 2G-PL	49

Drsnik GS H3G	49	Podložka US	66
Drsnik GS H3G-PL	49	Matica šestroba NT	66
Drsnik GS CC - H3G-PL	50	Matica prirobna NT FLA	66
Drsnik GS 41	50	Matica narebričena N	67
<b>6 Pritrditev za nosilce in trapezno pločevino</b>	<b>51</b>	Podaljšek navojni AD IG/IG	67
Konzola objemna SKL	51	Podaljšek okrogli AD RD	67
Spona za nosilec TCS F (VdS/FM)	51	Kos prehodni AD IG/AG	67
Spona za nosilec TCS	51	Redukcija navojna AD AG/IG	68
Spona za nosilec TCS 41	51	Navojni zatič GST	68
Plošča varovalna SL VdS	52	Navojni zatič GST 8.8	69
Zglob univerzalni UG	52	Navojni zatič PNS	69
Zglob SG	52	Klešče za PNS navojni zatič PBC	69
Zglob JOI S	52	Navojna palica GST 4.8	70
Zglob JOI R	53	Navojna palica BSK 5.8	70
Vpenjalni nastavek P	53	Navojna cev GR	70
Kljuka navojna GH	53	Protimatica NT G	70
Kljuka vpenjalna SP	53	Vložek zidni ANA	71
Streme vpenjalno SB 41	54	Vložek z žebljem ANH	71
Vložek obračalni KD	54	Vložek za votle stene ANC-M	71
Žaga luknjarica LS	54	Klešče montažne za ANC-M MZ	71
Nastavek za žago luknjarico ZBT	54	Plastično votla pritrditev ANC-K M4/12	72
Centrirni sveder ZB	55	Vložek previsni ANC-MK	72
Obešalo trapezno TRH	55	Vložek TBD m.S.	72
Vijak matični za trapez MSR	55	Vložek iz medenine ANM	72
Klešče za luknjanje LOT	55	Masa za sidranje VMU plus	73
Luknjalo LS LOT	56	Masa za sidranje VMZ	73
<b>7 Zvočno izolacijski elementi</b>	<b>57</b>	Masa za sidranje POLY SF	73
Zvočni dušilec SDE 0	57	Pribor VMZ / VMU plus	73
Zvočni dušilec SDE 1	57	Tulec sitasti PVC VMU - SH	74
Zvočni dušilec SDE 2 – SBV/SBZ	57	Vijak sidrni VMU-A	74
Zvočni dušilec SDE 2 - UG 16	57	Vijak sidrni VMZ-A	74
Zvočni dušilec SDE 2 - FP 1	58	Vijačno sidro TSM-ST	74
Akustični element AKE	58	Vijačno sidro TSM-S	75
Element gumijasti kovski GMT	58	Vijačno sidro TSM LP VZ 30	75
Profilna guma SAL SBR/EPDM	58	Nastavek BIT Torx 30	75
Profilna guma SAL EPDM sk	59	Sidro udarno AN	76
Profilna guma SAL Silikon	59	Vijačno sidro TSM-IM	76
Profilna guma SAL Silikon sk	59	Vijačno sidro TFF en kos	76
Trak samolepilni iz penaste gume MSK	59	Sidro AN BZ plus	77
Trak iz steklenih vlaken GSK	60	Sidro AN BZ3	78
<b>8 Vijaki, sidra in pribor</b>	<b>61</b>	Orodje za nameščanje sidro BWS	79
Vijak hanger brez vezi BSCR	61	Sidro udarno AN ES	79
Nastavek za vijak hanger ANT BIT	61	Razcepnik /Sveder za sidra ASW	79
Ploščica dvojna držalna DHP M8	61	Svod raziralni za udarna sidra ANT MSH	80
Spojnik dvojni navojni BOL M8	61	Sidro za votle strope AN Easy	80
Vijak SNK TG	62	Profilni žebelj PN 27	80
Vijak šestrobi lesni SKH	62	Kit silikonski SIK	80
Vijak lesni FLAH	62	<b>9 Fiksne točke</b>	<b>81</b>
Masa za sidranje VME plus	63	Sklop fiksne točke FPK	81
Masa za sidranje VMH	63	Plošča pritrjevalna FPKNO	81
Vijak očesni SCR	63	Plošča ravna FPFL-ST	81
Vijak ploščični SCR	63	Objemka fikse točke FS	81
Del cevni vpenjali SCB	64	Objemka hladilna za fiksno točko FKS	82
Vijak z vrtalno konico SKB	64	Tesnilna masa DP 30/45	82
Vijak samorezni SCR L	64	Tesnilna masa DP S-1035	82
Nastavek magnetni MN	64	Sklop povezovalni VP A/B	82
Vijak šestrobi SKT	65	Sklop povezovalni VP SDE 2	83
<b>10 Montažni sistem Pressix CC 27</b>	<b>84</b>	<b>10 Montažni sistem Pressix CC 27</b>	<b>84</b>
Montažni profil MS 27 – 1,25	84	Montažni komplet PBS CC 27	84

Blok PB 27	84		
Matica kljukasta NT CC 27	84		
Matica navojna NT 27	85		
Vijak s kljukasto glavo HM 27	85		
Zaključna kapica ADK 27	85		
Kotnik CN CC 27-90°	85		
Konzola previsna AK 27 - 1,25	86		
Montažni komplet MOS 27	86		
Držalo MOF 27	86		
Streme vpenjalno SB 27	86		
Ozobje kljukasto HK 27	87		
Profilna guma SAL 27	87		
Zvočni dušilec SDE 27	87		
<b>11 Tablice</b>	<b>88</b>		
Tablica z vpenjalnim trakom UNI M S	88		
Tablica brez vpenjanega traka UNI	88		
Tablica privarilna UNI	88		
Tablica privijalna SHT	88		
Trak vpenjalni LOH ALU	89		
Trak ježek KBD	89		
Pokrov plastični SHA	89		
Tablica barvna LOG	89		
Prazna letev SLL	90		
Vtisk	90		
Laserska obdelava	90		
<b>12 Izolacija</b>	<b>92</b>		
Izolacijska cev Climaflex CFX protect	92		
Izolacijska cev Climaflex CFX silence	92		
Izolacijski trak Climaflex CFX PE	92		
Izolacijska cev ISOST LX	93		
Izolacijski trak ISOST LX	93		
Flis za nosilce podstavkov SHB VL	93		
Climaflex CFX Natur	94		
Izolacijska plošča Kelon	95		
Climaflex CFX Natur Easy	95		
Climaflex CFX Natur Easy koleno	95		
Climaflex CFX Basic Stabil	96		
Climaflex CFX Natur Easy T-kos	96		
Climaflex CFX Natur Stabil	96		
Izolacijski trak CFX	97		
Lepilo CFX NMC-fix	97		
Spojka Climaflex CFX	97		
Eurobatex ETX C1 6 - 13 mm	98		
Eurobatex ETX C1 19 - 40 mm	99		
Izolacijska plošča Eurobatex C1	100		
Izolacijski trak Eurobatex	100		
Lepilo Eurobatex ETX CNX	100		
Izolacija v roli Eurobatex ETX C1	101		
Izolacija v roli Eurobatex ETX C1 SK	101		
Eurobatex AT Solar	101		
Lepilo Eurobatex AT N	102		
Čistilo za lepljenje izolacije	102		
Guma Silentplus Rubber SPR	102		
Izolacijski trak Anker	103		
Cevak ISA	103		
Lepilni trak Alltape	103		
Lepilni trak Sikla-Plast	104		
Lepilni trak Coroplast 918 Alu	104		
Lepilni trak Coroplast 910 Alu-SE	104		
Lepilni trak GKB	104		
<b>13 Nerjaveče jeklo</b>		<b>105</b>	
Vpenjalni nastavek SPA 5P VA		105	
Objemka vijajčna SRS VA		105	
Objemka vijajčna SRS VA z oblogo		106	
Objemka Stabil D - VA		106	
Objemka Stabil D-1G VA		107	
Objemka Stabil D-1G VA z oblogo		107	
Objemka Stabil D-1G VA Silikon		108	
Objemka Stabil B-M12 VA		108	
Objemka Stabil B VA		109	
Adapter AD IG/IG VA		109	
Streme navojno RUB VA		110	
Montažni profil MS VA		110	
Matica kljukasta NT CC 41 VA		110	
Matica kljukasta NT HZ 41 VA		111	
Objemka Stabil D-2G/-3G VA		111	
Matica navojna NT VA		111	
Vijak s kljukasto glavo TBO HZ 41 VA		112	
Ozobje kljukasto HK VA		112	
Opornik STR VA		112	
Držalo WBD VA		112	
Objemka Stabil D-2G/-3G z oblogo VA		113	
Kotnik montažni MW 90° W Stabil VA		113	
Kotnik montažni MW VA		113	
Konzola kotna WK VA		114	
Konzola previsna AK VA		114	
Objemka Stabil D-2G/-3G Silikon VA		114	
Osnovna plošča GPL VA		115	
Drsnik GS 2G VA		115	
Drsnik GS 2G-PL VA		115	
Drsnik GS H3G VA		115	
Drsnik GS H3G-PL VA		116	
Drsnik GS 41 VA		116	
Spona za nosilec TCS VA		116	
Zglob univerzalni UG VA		116	
Mufa očesna SCB VA		117	
Vijak hanger brez vezi BSCR VA		117	
Vijak šestrobe lesni SKH VA		117	
Vijak šestrobi SKT VA		117	
Podložka US VA		118	
Matica šestroba NT VA		118	
Podaljšek navojni AD IG/IG VA		118	
Kos prehodni AD IG/AG VA		118	
Navojna palica GST VA		119	
Navojna cev GR VA		119	
Vijak sidrni VMZ-A A4		119	
Sidro AN BZ plus A4		120	
Sidro AN BZ3 A4		120	
Udarno sidro AN VA		121	
<b>14 HCP – zaščita materiala</b>		<b>122</b>	
Objemka Stabil D-3G HCP		122	
Objemka Stabil D-3G z oblogo HCP		123	
Objemka Stabil RB-A HCP		124	
Adapter AD IG/IG HCP		124	
Pritrditev za streme UBF HCP		125	
Streme navojno RUB DIN 3570 A HCP		125	
Kotnik kanalni LUW HCP		126	
Montažni profil MS 41 HCP		126	
Matica kljukasta NT HZ 41 HCP		126	
Matica kljukasta NT CC 41 HCP		126	
Vijak s kljukasto glavo TBO HZ 41 HCP		127	

Ozobje kljukasto HK HCP	127	Matica šestroba NT HCP	135
Sklop za profil SK HCP	127	Matica prirobna NT SEC HCP	135
Sklop za profil SK-L HCP	127	Matica podaljšana AD IG/IG HCP	136
Držalo profila SH HCP	128	Navojni zatič GST HCP	136
Kotnik montažni MW HCP	128	Navojna palica GST HCP	136
Kotnik montažni MW S HCP	128	Navojna cev GR HCP	136
Bočna ojačitev CFB HCP	128	Protimatica NT G HCP	137
Konzola kotna WK HCP	129	Cink sprej ZS HCP	137
Kotni spojnik EW 41-1 HCP	129		
Kotni spojnik EV CC 41-1 HCP	129	<b>15 Montažni sistem siMetrix 46</b>	<b>138</b>
Kotni spojnik EV CC 41-2 HCP	129	Montažni profil PRO 46	138
Kotni spojnik EV CC 41-3 HCP	130	Konzola previsna AK 46-P	138
Kotni spojnik EV CC 41-4 HCP	130	Konzola previsna AK CC 46-P	138
Kotni spojnik EV CC 41-5 HCP	130	Spojnik CN 46	138
Držalo WBD HCP	130	Držalo WBD 46	139
Držalo WBD-C HCP	131	Adapter montažni profil 80/100 na PRO 46	139
Podnožje SHB HCP	131	Adapter montažni profil 27/41 na PRO 46	139
Konzola previsna AK HCP	131	Montažno držalo profila MPH 46	139
Osnovna plošča GPL HCP	131	Streme vpenjalno SB 46	140
Zglob JOI 41 T HCP	132	Adapter PK 46	140
Zglob JOI 41 HCP	132	Adapterska plošča AP 46	140
Spona za nosilec TCS HCP	132	Podnožje SHB SQF 46	140
Spona za nosilec TCS 41 HCP	133	Drsnik GS H3G-PL 46	141
Drsnik GS 2G-PL HCP	133	Streme navojno RUB 46	141
Streme vpenjalno SB 41 HCP	133	Klema za objemke MPK 46	141
Vpenjalni nastavek SPA 5P HCP	133	Blok PBH 46	142
Vpenjalni nastavek SPA 5P AU HCP	134	Montažni komplet PBS 46	142
Vpenjalni komplet SPZ HCP	134	Zaključna kapica ADK 46	142
Navojno držalo GWB HCP	134	Profilna guma SAL 46	143
Vijak šestrobi SKT HCP	134	Drсна podloga GA 41-46	143
Vijak s prirobno SCR FLA HCP	135	Bočna ojačitev CFB 46	143
Podložka US HCP	135	Križni drsnik KGL 46	143

Produkt

Artikel

Pakirano

Artikel-št.

**Objemka ERS ME**

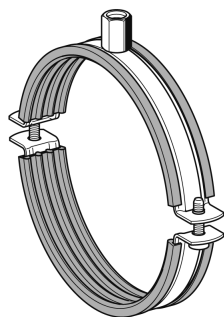

**Skupina: 1206**

11 - 15	M8/M10	200	116766
20 - 24	M8/M10	170	116768
25 - 28	M8/M10	130	116769
32 - 35	M8/M10	120	116771
48 - 53	M8/M10	70	116773
75 - 80	M8/M10	60	116776
87 - 92	M8/M10	50	116777

**Objemka Ratio S M8**

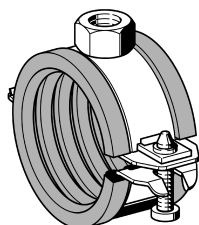

**Skupina: 1234**

17 - 19	$\frac{3}{8}$ "	100	157366
31 - 38	1"	100	157320
58 - 63	2"	50	191864

**Objemka Ratio LS**

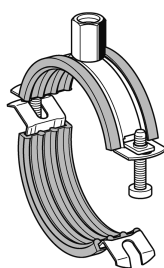

**Skupina: 1245**

64 - 71		25	157472
83 - 90	3"	25	157490

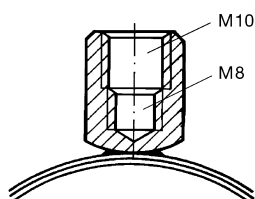

Produkt

Artikel

Pakirano

Artikel-št.

**Objemka Ratio LS Silikon**

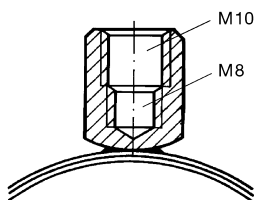
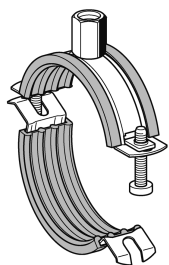

**Skupina: 1244**

12 - 20	$1/4'' - 3/8''$	100	166401
21 - 27	$1/2'' - 3/4''$	100	166410
28 - 35	1"	100	166429
38 - 45	$1 1/4''$	50	166438
48 - 56	$1 1/2''$	50	166447
57 - 63	2"	50	166456
64 - 71		25	166465
74 - 84	$2 1/2''$	25	166474
83 - 90	3"	25	166483

**Objemka Ratio S**

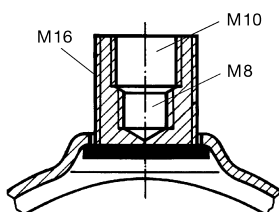
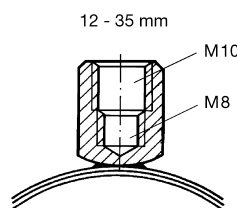
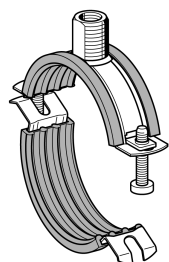

**Skupina: 1231**

12 - 20	$1/4'' - 3/8''$	100	154804
21 - 27	$1/2'' - 3/4''$	100	154813
28 - 35	1"	100	154822
38 - 45	$1 1/4''$	50	154831
48 - 56	$1 1/2''$	50	154840
57 - 63	2"	50	154859
64 - 71		25	154868
73 - 80	$2 1/2''$	25	154877
83 - 90	3"	25	154886
108 - 114	4"	25	154895
116 - 125		25	154901
127 - 135		25	154910
140 - 146	5"	25	154929
159 - 170	6"	25	154938

Produkt

Artikel

Pakirano

Artikel-št.

**Objemka drsna Ratio S-K**

**Skupina: 1235**

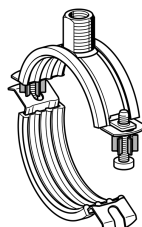

16 - 32 mm

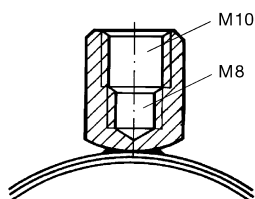

40 - 110 mm

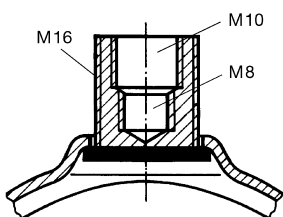

**Objemka Ratio 3G**

**Skupina: 1237**

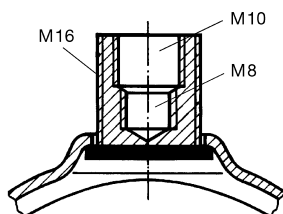
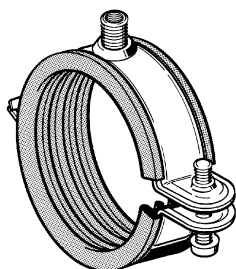

16	100	148771
20	100	148780
25	100	148799
32	100	148805
40	50	148814
50	50	148823
56	50	148832
63	50	148841
75	25	148850
90	25	155993
110	25	156000

13 - 16	15	100	120519
17 - 19	3/8"	100	120528
20 - 23	1/2"	100	120537
25 - 30	3/4"	100	120546
31 - 37	1"	100	120555
40 - 45	1 1/4"	50	120564
48 - 53	1 1/2"	50	120573
54 - 59	57	50	120582
60 - 64	2"	50	120591
70 - 76	2 1/2"	25	120616
77 - 83	83	25	120625
83 - 90	3"	25	120634
108 - 114	4"	25	120652
133 - 141	5"	25	120661
159 - 168	6"	25	120670



Produkt

Artikel

Pakirano

Artikel-št.

**Objemka vijačna SRS 2G brez obloge**

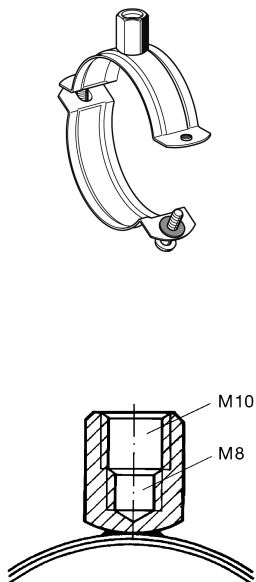

**Skupina: 1223**

13 - 18	100	173216
19 - 22	100	173225
23 - 26	100	111470
27 - 30	100	173234
32 - 36	100	173243
40 - 44	50	173252
48 - 54	50	173261
55 - 59	50	182990
60 - 66	50	173279
68 - 73	25	173288
75 - 80	25	173297
84 - 89	25	173306
90 - 98	25	186023
94 - 101	25	186032
102 - 108	25	173315
110 - 115	25	173324
118 - 125	25	186041
129 - 136	25	191387
138 - 144	25	191396
144 - 153	25	191405
159 - 167	25	191414

**Objemka Stabil D-1/2" brez obloge**

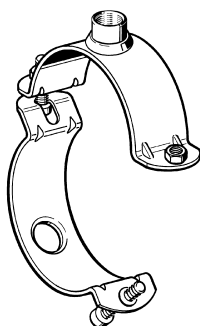

**Skupina: 1220**

20 - 24	1/2"	50	400927
25 - 30	3/4"	50	400936
31 - 35	1"	50	400945
40 - 45	1 1/4"	50	400963
48 - 53	1 1/2"	50	400972
54 - 59		50	402007
60 - 65	2"	50	400999
67 - 72		50	401008
76 - 81	2 1/2"	25	401026
88 - 93	3"	25	401044
102 - 108		25	401071
110 - 116	4"	10	401080
124 - 129		10	401089
133 - 140		10	401098
140 - 148	5"	10	401107
149 - 155		10	401116
159 - 165		10	402025
167 - 173	6"	10	401134
176 - 184		10	401143
188 - 194		10	412006
199 - 205		10	401152
205 - 214		10	412015
219 - 225	8"	10	412024
244 - 250		10	412033
267 - 273	10"	10	412042
278 - 284		10	412051
297 - 303		10	412060



Produkt

Artikel

Pakirano

Artikel-št.

**Objemka Stabil D-3G**

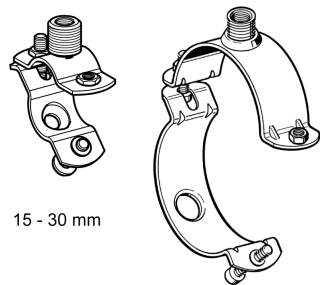

15 - 30 mm

31 - 72 mm

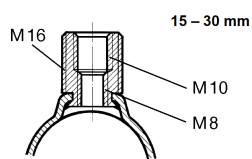

15 - 129 mm:

M16/M10/M8

133 - 316 mm:

1/2"/M16/M12

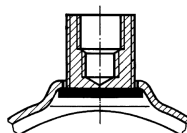

**Skupina: 1240**

15 - 19	3/8"	50	107705
20 - 24	1/2"	50	107714
25 - 30	3/4"	50	107723
31 - 35 *	1"	50	107015
40 - 45 *	1 1/4"	50	107024
48 - 53 *	1 1/2"	50	107033
54 - 59 *		50	107042
60 - 65 *	2"	50	107051
67 - 72 *		50	107060
76 - 81 M *	2 1/2"	25	115759
82 - 87 M *		25	115761
88 - 93 M *	3"	25	115762
102 - 108 M *		25	115763
110 - 116 M *	4"	25	115764
124 - 129 M *		25	115766
133 - 140 *		10	107130
140 - 148 *	5"	10	115885
149 - 155 *		10	107149
159 - 165 *		10	107158
167 - 173 *	6"	10	107167
176 - 184		10	107176
188 - 194		10	107185
199 - 205		10	107194
207 - 216		10	148939
219 - 225	8"	10	107200
244 - 250		10	107219
267 - 273	10"	10	107228
278 - 284		10	107237
297 - 303		10	107246
310 - 316		10	147600





Produkt

Artikel

Pakirano

Artikel-št.

**Objemka Stabil D-3G Silikon**

**Skupina: 1242**

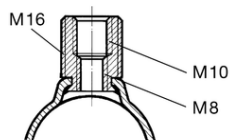
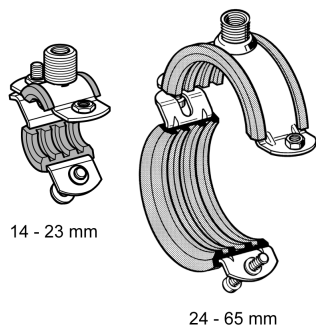

14 - 115 mm:  
M16/M10/M8  
124 - 305 mm:  
1/2" M16/M12

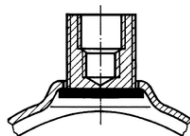

14 - 18	3/8"	50	108070
19 - 23	1/2"	50	108089
24 - 28	3/4"	50	108098
29 - 33	1 "	50	108104
33 - 37		50	108113
40 - 45	1 1/4"	50	108122
47 - 52	1 1/2"	50	108131
53 - 58		50	108140
60 - 65	2"	50	108159
67 - 72 M		25	115801
73 - 78 M	2 1/2"	25	115802
79 - 85 M		25	115804
88 - 93 M	3"	25	115805
100 - 106 M		25	115806
108 - 115 M	4"	25	115807
124 - 129		10	108229
131 - 137		10	108238
138 - 144	5"	10	108274
148 - 154		10	108283
156 - 162		10	108292
165 - 171	6"	10	108308
177 - 183		10	108317
188 - 194		10	108326
196 - 203		10	154947
205 - 214		10	149879
219 - 225	8"	10	108335
244 - 250		10	108344
267 - 273	10"	10	108353
299 - 305		10	108362



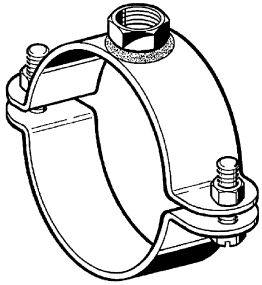
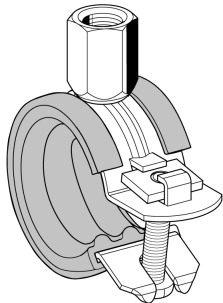

Produkt	Artikel	Pakirano	Artikel-št.
<b>Objemka Stabil D-M16</b> 	<b>Skupina: 1232</b>		
	19 - 23	50	118268
	26 - 30	50	118277
	33 - 38	50	118295
	39 - 44	50	118301
	45 - 50	50	118310
	54 - 58	50	118329
	60 - 64	50	118338
	65 - 72	25	118620
	70 - 77	25	118639
	85 - 92	25	118648
	97 - 104	25	118657
	105 - 108	25	104058
	110 - 117	25	118666
	118 - 125	25	400343
	122 - 129	25	118684
	133 - 140	10	118693
	148 - 155	10	118709
	158 - 165	10	118718
	168 - 175	10	118727
	173 - 180	10	118736
	188 - 195	10	118745
	195 - 202	10	118754
	208 - 215	10	118763
	218 - 227	10	118772
	228 - 235	10	118781
	245 - 252	10	118790
	258 - 265	10	118806
	271 - 277	10	118198
	285 - 291	10	118204
	318 - 326	1	103844
	348 - 356	1	103862
360 - 368	1	103871	
399 - 407	1	103905	
411 - 419	1	103914	
500 - 508	1	103941	
513 - 521	1	103950	
<b>Objemka LRS</b> 	<b>Skupina: 8410</b>		
	8 - 11	150	806086
	12 - 14	150	806087
	15 - 19	100	806088
	20 - 24	100	806089
	25 - 30	100	806090
	31 - 38	75	806091
	39 - 43	50	806092
	44 - 49	50	806093
	50 - 55	50	806094
	56 - 61	50	806095
	62 - 67	25	806096
	68 - 73	25	806097
	74 - 80	25	806098
	89 - 95	25	806099
107 - 115	20	806100	













Produkt

Artikel

Pakirano

Artikel-št.

**Objemka hladilna LKS 19**

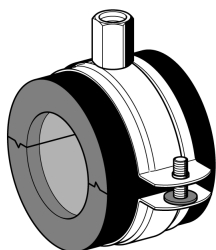

**Skupina: 1255**

LKS 19-15	M8/M10	42	114730
LKS 19-16 *	M8/M10	42	114731
LKS 19-18	M8/M10	42	114733
LKS 19-20 *	M8/M10	42	114734
LKS 19-22	M8/M10	42	114735
LKS 19-25	M8/M10	42	114736
LKS 19-26 *	M8/M10	42	114737
LKS 19-28	M8/M10	36	114738
LKS 19-32 *	M8/M10	36	114740
LKS 19-35	M8/M10	24	114741
LKS 19-40 *	M8/M10	24	114743
LKS 19-42	M8/M10	24	114744
LKS 19-48	M8/M10	18	114746
LKS 19-50 *	M8/M10	18	114747
LKS 19-54	M8/M10	18	114748
LKS 19-60	M8/M10	18	114751
LKS 19-64	M8/M10	18	114752
LKS 19-76	M8/M10	18	114754
LKS 19-89	M8/M10	10	114756
LKS 19-108	M8/M10	10	114758
LKS 19-114	M8/M10	8	114760
LKS 19-89 A	M12/M16 <sup>1/2</sup> "	10	416680
LKS 19-108 A	M12/M16 <sup>1/2</sup> "	8	416681
LKS 19-110 A	M12/M16 <sup>1/2</sup> "	8	416682
LKS 19-114 A	M12/M16 <sup>1/2</sup> "	8	416683
LKS 19-125 A	M12/M16 <sup>1/2</sup> "	6	416684
LKS 19-139	M12/M16 <sup>1/2</sup> "	6	114763
LKS 19-160	M12/M16 <sup>1/2</sup> "	6	114764
LKS 19-168	M12/M16 <sup>1/2</sup> "	6	114765
LKS 19-180	M12/M16 <sup>1/2</sup> "	6	114766
LKS 19-219	M12/M16 <sup>1/2</sup> "	6	114768
LKS 19-225	M12/M16 <sup>1/2</sup> "	6	114769
LKS 19-250	M12/M16 <sup>1/2</sup> "	2	114770
LKS 19-273	M16	2	114771





Produkt

Artikel

Pakirano

Artikel-št.

**Objemka hladilna SKS Top-2C**

**Skupina: 1250**

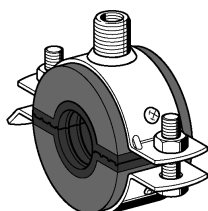

17 - 172 mm:  
M16/M10/M8  
219 - 327:  
½"/M16/M12

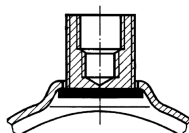

17 - 22	3/8" - 1/2"	50	191207
23 - 26		50	194980
27 - 32	3/4"	50	191216
33 - 38	1"	50	191225
38 - 42		25	194997
42 - 47	1 1/4"	25	191234
48 - 54	1 1/2"	25	191243
57 - 62	2"	25	191252
63 - 68		25	195000
70 - 75		25	191261
76 - 81	2 1/2"	25	191279
89 - 94	3"	25	191288
107 - 112		10	191297
113 - 117	4"	10	191306
125 - 128		10	195048
133 - 137		10	191315
138 - 142	5"	10	191324
157 - 161		10	191333
168 - 172	6"	10	191342
219 - 222	8"	1	191351
272 - 275	10"	1	191369
324 - 327		1	191378









Produkt

Artikel

Pakirano

Artikel-št.

**Adapter AD IG/IG**

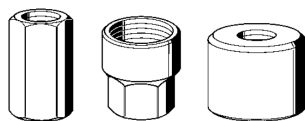

**Skupina: 1333**

M16/M10	50	106740
M16/M12	50	124665
M16/M16	50	106290
1/2"/M10	10	146371
1/2"/M16	25	124656
1/2"/1/2"	10	146380
3/4"/M16	10	105660
3/4"/1/2"	10	146399
1"/M16	10	105688
1"/1/2"	10	146405
M16/1/2"	25	157922

**Cevna zanka RSL N**

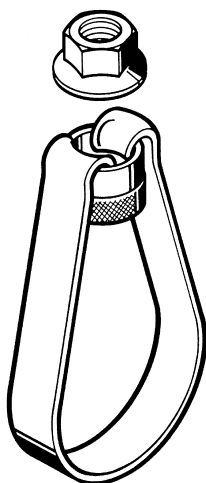

**Skupina: 1115**

26,9	3/4"	M8 (VdS)	100	113336
33,7	1"	M8 (VdS)	100	102287
42,4	1 1/4"	M8 (VdS)	50	102296
48,3	1 1/2"	M8 (VdS)	50	102302
60,3	2"	M8 (VdS)	50	102311
26,9	3/4"	M10 (FM)	100	113414
33,7	1"	M10 (FM)	100	102126
42,4	1 1/4"	M10 (FM)	50	102135
48,3	1 1/2"	M10 (FM)	50	102144
60,3	2"	M10 (FM)	50	102153
76,1	2 1/2"	M10	25	102320
88,9	3"	M10	25	102339
108		M10	25	102348
114,3	4"	M10	25	102357
133		M12	25	102366
139,7	5"	M12	25	102375
159		M12	25	102384
168,3	6"	M12	25	102393
219,1	8"	M16	10	102409

Produkt

Artikel

Pakirano

Artikel-št.

**Streme navojno RUB**

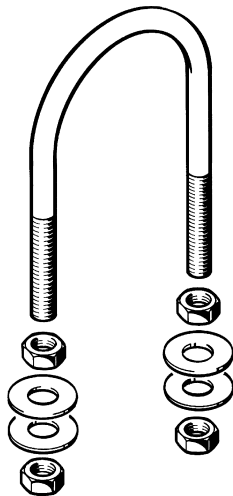

**Skupina: 1211**

21,3	1/2"	M8	50	102162
26,9	3/4"	M8	50	102773
33,7	1"	M8	50	102782
42,4	1 1/4"	M8	50	102791
48,3	1 1/2"	M8	50	102807
60,3	2"	M10	50	102816
76,1	2 1/2"	M10	50	102825
88,9	3"	M10	50	102834
108		M12	50	102843
114,3	4"	M12	25	102171
133		M12	25	102852
139,7	5"	M12	25	102180
159		M12	25	102861
168,3	6"	M12	10	102199
219,1	8"	M12	10	102870

Produkt

Artikel

Pakirano

Artikel-št.

**Objemka zračna PLU TOP 2G z oblogo**

**Gruppe: 1623**

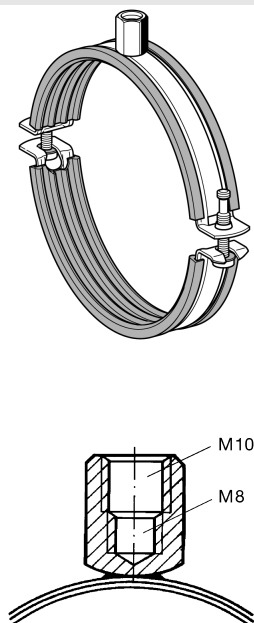

71	50	111783
80	50	111785
90	50	111786
100	100	111787
112	100	111788
125	100	111789
140	70	111790
150	70	111791
160	70	111792
180	50	111794
200	50	111795
224	50	111796
250	40	111797
280	40	111798
300	40	111799
315	40	111800
355	40	111801
400	30	111802
450	20	111803
500	20	111804

**Objemka zračna PLU 2G z oblogo**

**Skupina: 1602**

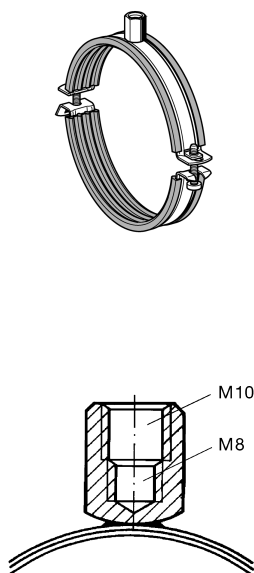

80	50	180452
90	50	180461
100	50	180470
112	25	180479
125	25	180488
140	25	180497
150	25	180506
160	25	180515
180	25	180524
200	25	180533
224	10	180542
250	10	180551
280	10	180560
300	10	180569
315	10	180578
355	10	180587
400	10	180596
450	10	180605
500	10	180614



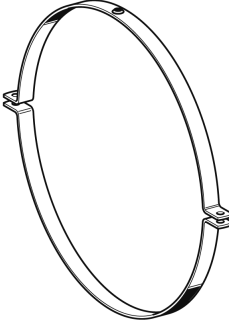
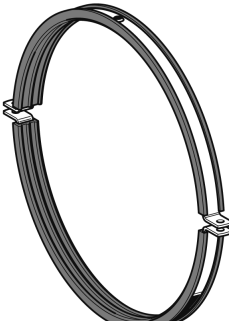

Produkt	Artikel	Pakirano	Artikel-št.
<b>Objemka zračna brez obloge od DN 560</b> 	<b>Skupina: 1602</b>		
	560	1	121848
	600	1	149116
	630	1	121857
	710	1	121866
	800	1	121875
	900	1	121884
	1000	1	121893
	1120	1	121909
	1250	1	121918
<b>Objemka zračna z oblogo od DN 560</b> 	<b>Skupina: 1602</b>		
	560	1	190181
	600	1	190199
	630	1	190208
	710	1	190217
	800	1	190226
	900	1	190235
	1000	1	190244
	1120	1	190253
	1250	1	190262

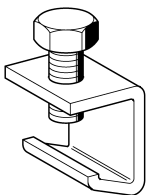
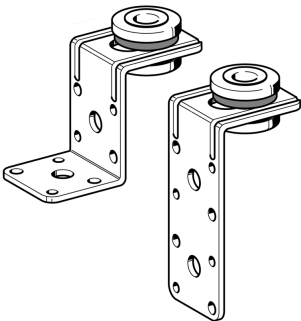
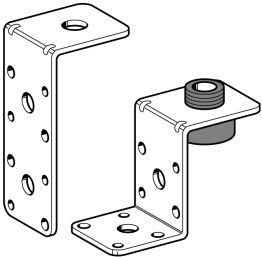
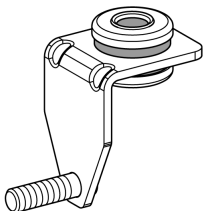

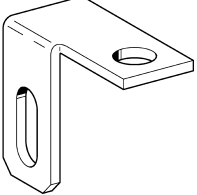
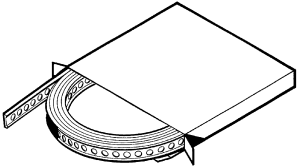
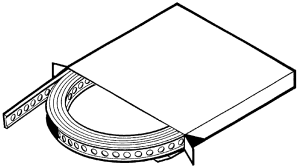
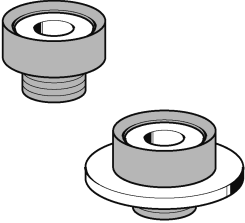

Produkt	Artikel	Pakirano	Artikel-št.
<b>Žabica LCO 30/40</b> 	<b>Skupina: 1604</b>		
	LCO 30/40	100	413707
<b>Kotnik kanalni LUW</b> 	<b>Skupina: 1601</b>		
	SL	100	189893
	SZ	100	189902
<b>Kotnik kanalni LUW A</b> 	<b>Skupina: 1621</b>		
	A-L	100	110496
	A-Z	100	110498
	A-SL	100	110497
	A-SZ	100	110499
<b>Kotnik kanalni LUW F</b> 	<b>Skupina: 1605</b>		
	F M8	100	113331
	SF M8	100	113329
	SF M10	100	113330

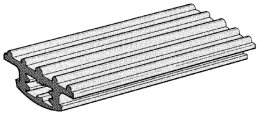
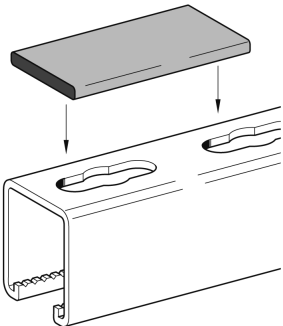
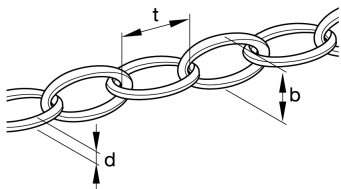
Produkt	Artikel	Pakirano	Artikel-št.
<b>Kotnik vezni FLW</b> 	<b>Skupina: 1601</b>		
	levo	100	406360
	desno	100	406361
<b>Trak perforiran pocinkan - BND</b> 	<b>Skupina: 1129</b>		
	12 x 0,7	10	120892
	17 x 0,7	10	120908
<b>Trak perforiran PVC - BND</b> 	<b>Skupina: 1129</b>		
	19	10	121015
<b>Zvočno izolacijski element SDE</b> 	<b>Skupina: 2712 / 1610</b>		
	41	100	107802
	B	100	410458



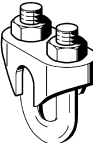

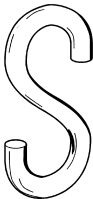
Produkt	Artikel	Pakirano	Artikel-št.
<b>Profilna guma SAL</b>	<b>Skupina: 1611</b>		
	41	30	101189
	41/L50	-	101204
			
<b>Profilna guma SAL SK</b>	<b>Skupina: 1611</b>		
	SK 40 x 5	10	410341
			
<b>Veriga GLK</b>	<b>Skupina: 1345</b>		
	3 x 20	40	402997
			
<b>Jeklena vrv SDS</b>	<b>Skupina: 1345</b>		
	2 mm	40	415102
	4 mm	40	403762
			

Produkt	Artikel	Pakirano	Artikel-št.
<b>Zanka za jekleno vrv DSK</b>	<b>Skupina: 1345</b>		
	2 mm	100	415111
	4 mm	100	403744
			
<b>Klema za jekleno vrv DSL</b>	<b>Skupina: 1345</b>		
	2 mm	100	415120
	4 mm	100	403753
			
<b>Člen za spajanje verige SGL</b>	<b>Skupina: 1345</b>		
	4 x 24	100	402043
			
<b>Kljuka-S SHK</b>	<b>Skupina: 1345</b>		
	6 x 44	100	402070
			





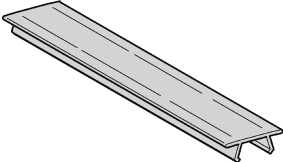
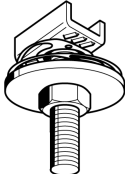

Produkt	Artikel	Pakirano	Artikel-št.	
<b>Pokrov za profile MSA</b>	<b>Skupina: 1304</b>			
	MSA 41	2	180623	
	<b>Skupina: 1309</b>			
	M8 x 35	25	191549	
	M8 x 75	25	191558	
	M8 x 125	25	191567	
	M8 x 175	25	191576	
	M8 x 275	25	191585	
	M10 x 35	25	191594	
	M10 x 75	25	191603	
	M10 x 125	25	191612	
	M10 x 175	25	191621	
	M10 x 275	25	191639	
	<b>Montažni komplet SCAD</b>	<b>Skupina: 1309</b>		
		M10 x 40	1	602202
		M16 x 35	1	602281
	<b>Skupina: 1308</b>			
	M8	50	198988	
	M10	50	198995	
	M12	50	199008	
<b>Blok PBH 41</b>				
				

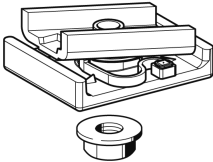
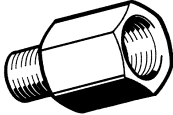
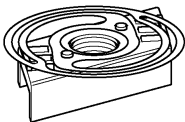
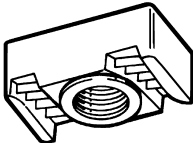
Produkt	Artikel	Pakirano	Artikel-št.
<b>Blok PB 41</b> 	<b>Skupina: 1308</b>		
	M8	50	160380
	M10	50	160399
	M12	50	171287
<b>Priključni kos ASS M16</b> 	<b>Skupina: 1960</b>		
	M16/M10 L	50	161105
<b>Matica kljukasta NT CC 41</b> 	<b>Skupina: 1314</b>		
	CC 41-M8	50	180209
	CC 41-M10	50	180218
	CC 41-M12	50	182252
	CC 41-M16	50	182261
<b>Matica kljukasta NT HZ 41</b> 	<b>Skupina: 1314</b>		
	HZ 41-M8	50	151935
	HZ 41-M10	50	151944
	HZ 41-M12	50	182288
	HZ 41-M16	50	182297

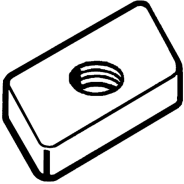
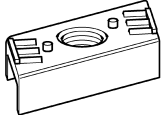
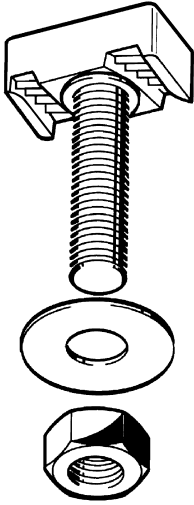

Produkt	Artikel	Pakirano	Artikel-št.	
<b>Matica navojna NT</b>    	<b>Skupina: 1314</b>			
	L 41-M8	100	405427	
	L 41-M10	100	405436	
	41-M8	50	180173	
	41-M10	50	180182	
<b>Vijak s kljukasto glavo TBO HZ 41</b>  	<b>Skupina: 1311</b>			
	HZ 41 M 8 x 20	50	151962	
	HZ 41 M 8 x 25	50	151971	
	HZ 41 M 8 x 35	50	151980	
	HZ 41 M 8 x 55	50	151999	
	HZ 41 M 8 x 75	50	152006	
	HZ 41 M 8 x 95	50	152015	
	HZ 41 M 10 x 20	50	152033	
	HZ 41 M 10 x 25	50	152042	
	HZ 41 M 10 x 35	50	152051	
	HZ 41 M 10 x 55	50	152060	
	HZ 41 M 10 x 75	50	152079	
	HZ 41 M 10 x 95	50	152088	
	HZ 41 M 12 x 25	50	152176	
	HZ 41 M 12 x 35	50	152185	
	HZ 41 M 12 x 55	50	152194	
	HZ 41 M 12 x 75	50	152200	
	HZ 41 M 12 x 95	50	152219	
	HZ 41 M 16 x 25	50	152228	
	HZ 41 M 16 x 35	50	152237	
	HZ 41 M 16 x 55	50	152246	
	HZ 41 M 16 x 75	50	152255	
	HZ 41 M 16 x 95	50	152264	

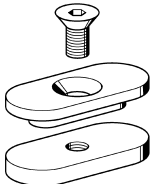
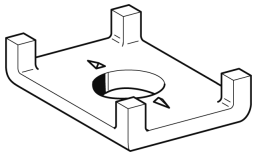
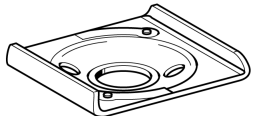
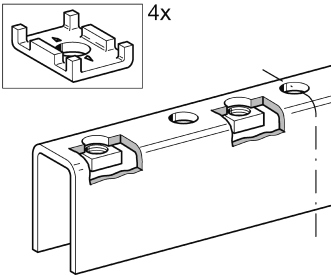
Produkt	Artikel	Pakirano	Artikel-št.
<b>Vezni element za montažne profile KL</b>	<b>Skupina: 1357</b>		
	KL 1	50	118055
			
<b>Ozobje kljukasto HK</b>	<b>Skupina: 1327</b>		
	41/10	50	178247
	41/12	50	178256
	41/16	50	178265
			
<b>Ozobje kljukasto HK BL</b>	<b>Skupina: 1327</b>		
	BL 8	100	110500
	BL 10	100	110501
	BL 12	100	110502
			
<b>Sklop za profil SK</b>	<b>Skupina: 1353</b>		
	SK 41/21-31	10	177599
	SK 41/41-45	10	155115
	SK 41/52	10	177608
	SK 41/62	10	155124
	SK 41-75/65	10	177617
	SK 41-75/75	10	177626
			



Produkt

Artikel

Pakirano

Artikel-št.

**Držalo profila SH**

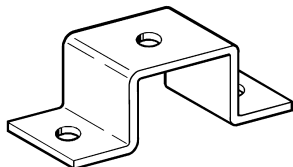

**Skupina: 1112**

41/21	50	177338
41/31	50	113645
41/41 u. 41/21 D	50	177365
41/45	50	126791
41/52	50	177347
41/62	25	177356
41-75/65	25	177644
41-75/75	25	177662
41/41 D	10	177374
41/52 D	10	177383
41/62 D	10	163000
41-75/65 D	10	177671
41-75/75 D	10	177680

**Montažni komplet MOS**

levo: MH, desno MV

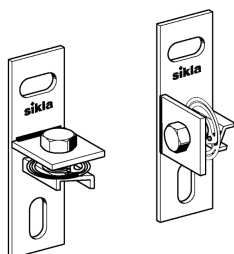

**Skupina: 1330**

MH 41	10	143800
MV 41	10	143794

**Montažni komplet MOS CC**

levo: MH, desno MV

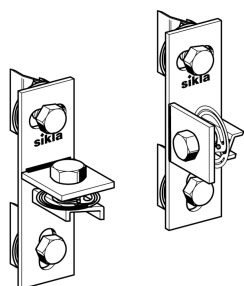

**Skupina: 1330**

CC - MH 41	10	191756
CC - MV 41	10	191765

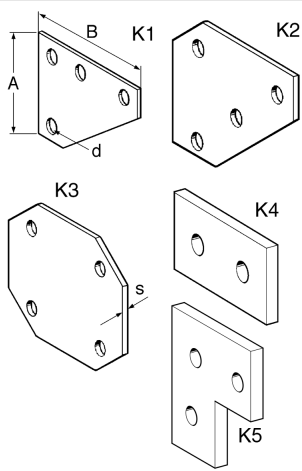
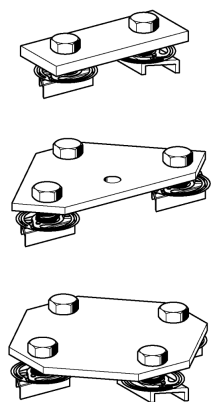
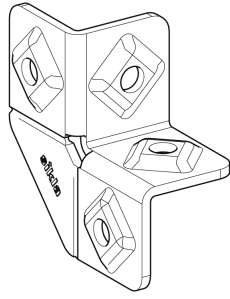
Produkt	Artikel	Pakirano	Artikel-št.
<b>Vozliščna plošča KNO</b>			
	<b>Skupina: 1351</b>		
	KNO 1	10	107769
	KNO 2	10	107778
	KNO 3	10	107787
	KNO 4	100	163347
	KNO 5	10	406990
<b>Plošča kotna ECO CC</b>			
	<b>Skupina: 1351</b>		
	CC-1	20	181190
	CC-2	10	181199
CC-3	10	181208	
<b>Kotni spojnik EW 41-1</b>			
	<b>Skupina: 1352</b>		
	EW 41-1	25	117336

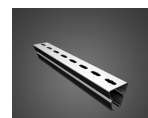

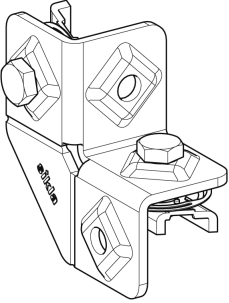
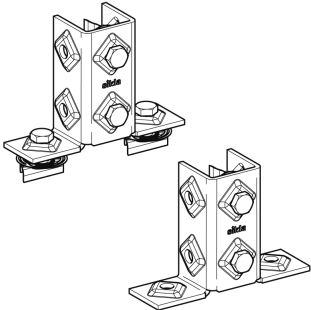
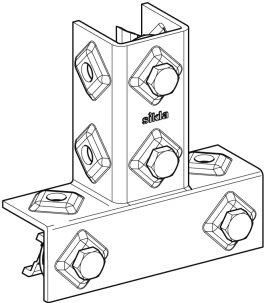
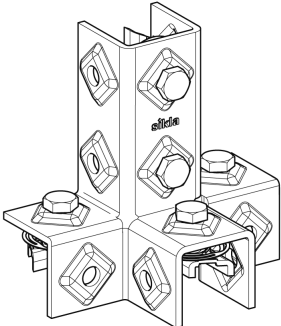
Produkt	Artikel	Pakirano	Artikel-št.
<b>Kotni spojnik EV CC 41-1</b> 	<b>Skupina: 1352</b>		
	EV CC 41-1	25	117338
<b>Kotni spojnik EV CC 41-2</b> 	<b>Skupina: 1352</b>		
	EV CC 41-2	10	117456
	EV CC 41-2 W	10	117458
<b>Kotni spojnik EV CC 41-3</b> 	<b>Skupina: 1352</b>		
	EV CC 41-3	10	117460
<b>Kotni spojnik EV CC 41-4</b> 	<b>Skupina: 1352</b>		
	EV CC 41-4	10	117463

Produkt

Artikel

Pakirano

Artikel-št.

**Kotni spojnik EV CC 41-5**

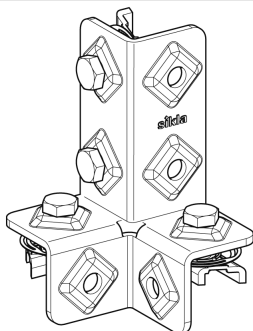

**Skupina: 1352**

EV CC 41-5

10

117465

**Distančnik HRS P**

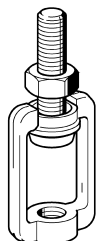

**Skupina: 1339**

P M8

25

151519

P M10

25

151528

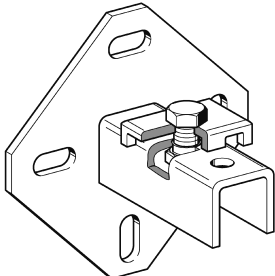
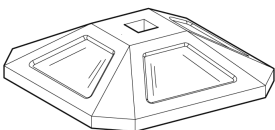
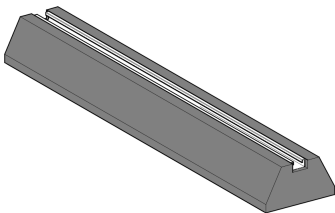
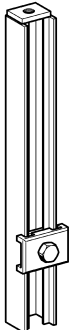

Produkt	Artikel	Pakirano	Artikel-št.
<b>Držalo - WBD</b> 	<b>Skupina: 1356</b>		
	41/21-31	10	177725
	41/41-45	10	155054
	41/52	5	177734
	41/62	5	155063
	41-75/65	5	177743
	41-75/75	5	177752
	41/21 D	5	146469
	41/41-45 D	5	106768
	41/52 D	5	177761
	41/62 D	5	155090
	41-75/65 D	5	177770
	41-75/75 D	5	177779
	<b>Podnožje SHB SQF 41</b> 	<b>Skupina: 1377</b>	
SHB SQF 41-350		1	218875
SHB SQF 41-500		1	218881
SHB SQF 41 D-350		1	218876
SHB SQF 41 D-500		1	218882
<b>Podnožje SHB SQF-41L</b> 	<b>Skupina: 1377</b>		
	SQF 41 L-250	1	218877
	SQF 41 L-400	1	218878
	SQF 41 L-600	1	218883
	SQF 41 L-1000	1	218880
	SQF SET 41 L - 250	1	408600
	SQF SET 41 L - 400	1	408601
	SQF SET 41 L - 600	1	408602
	SQF SET 41 L - 1000	1	408603
	<b>Profilni teleskop ST 41</b> 	<b>Skupina: 1356</b>	
ST 41		25	189740

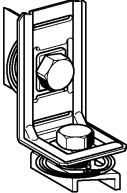
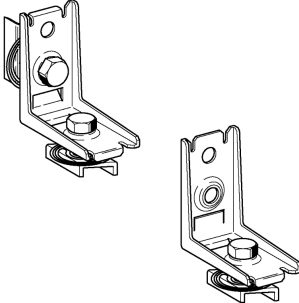
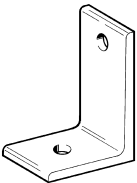
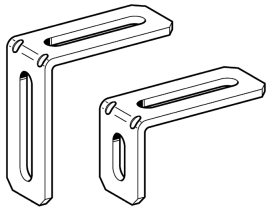
Produkt	Artikel	Pakirano	Artikel-št.
<b>Kotnik CN CC 41-90°</b>	<b>Skupina: 1326</b>		
	CC 41-90°	25	180236
	<b>Skupina: 1326</b>		
	CC 41-90° Stabil	25	191675
	CC 41-90° W Stabil	25	191684
	CC 41-45° Stabil	25	191882
	CC 41-45° W Stabil	25	191891
	<b>Skupina: 1326</b>		
	45/30/90°	50	115380
	60/40/90°	25	115399
	90/60/90°	25	114820
	55/55/90 BSK	50	415822
	<b>Skupina: 1326</b>		
	95/55/90°	25	172388
	95/95/90°	25	172397
	<b>Skupina: 1326</b>		
	95/55/90°	25	172388
	95/95/90°	25	172397

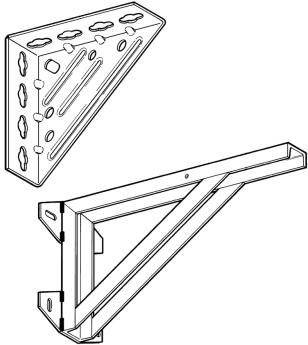
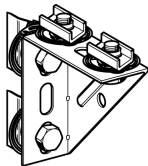
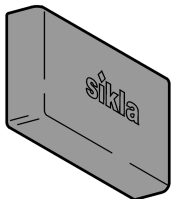
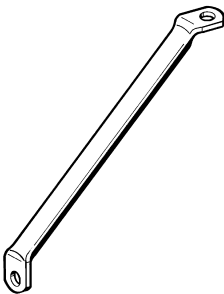

Produkt	Artikel	Pakirano	Artikel-št.
<b>Konzola kotna WK</b>			
	<b>Skupina: 1326 / 1826</b>		
	100/100	25	145626
	100/100-40	25	163921
	150/150	25	155513
	200/200	10	118170
	300/200	1	118046
	550/350	1	145635
	725/400	1	151041
880/550	1	151050	
<b>Konzola kotna WK CC</b>			
	<b>Skupina: 1326</b>		
	CC 100/100-40	25	191774
	CC 150/150	10	191783
<b>Zaključna kapica ADK WK</b>			
Za kotno konzolo 300/200 und 550/350	<b>Skupina: 1304</b>		
	WK 300 - 550	50	101055
			
	<b>Opornik STR</b>		
Primeren tudi za stransko oporo kotne konzole	<b>Skupina: 1326</b>		
	300/200	10	125967
	550/350	10	125994
	725/400	10	151908
	880/550	10	151892

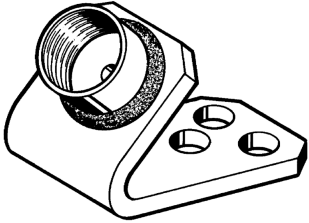
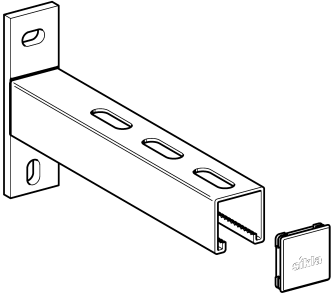
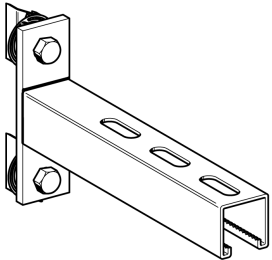
Produkt	Artikel	Pakirano	Artikel-št.
<b>Konzola oporna ST</b> 	<b>Skupina: 1355</b>		
	1/2" - 45	25	143828
	3/4" - 45	25	143837
	1" - 45	25	143846
	1/2" - 90	25	148744
<b>Konzola previsna AK</b> 	<b>Skupina: 1354 / 2754</b>		
	41/41 - 200	10	115609
	41/41 - 260	10	153973
	41/41 - 320	10	115618
	41/41 - 445	10	115627
	41/41 - 570	10	115636
	41/41 - 820	1	149268
	41/41 - 1010	1	149277
	41/62 - 320	10	113296
	41/62 - 445	10	113297
	41/62 - 570	10	113298
	41/62 - 820	1	113299
	41/62 - 1010	1	113300
	<b>Konzola previsna AK CC</b> 	<b>Skupina: 1354</b>	
CC 41/41-200		10	191792
CC 41/41-260		10	191801
CC 41/41-320		10	191819
CC 41/41-445		10	191828
CC 41/41-570		10	191837
CC 41/41-820		1	191846
CC 41/41-1010		1	191855

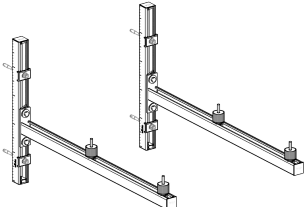
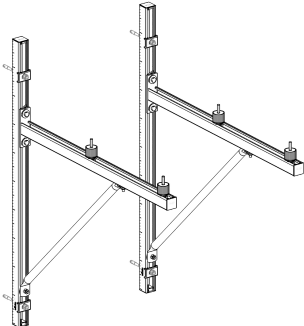
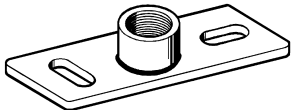
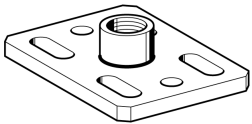

Produkt	Artikel	Pakirano	Artikel-št.	
<b>Set konzole KIT A</b> 	<b>Skupina: 7101</b>			
	445	1	404060	
	570	1	404061	
	820	1	404062	
	1010	1	404063	
<b>Set konzole KIT B</b> 	<b>Skupina: 7101</b>			
	820	1	404064	
	1010	1	404065	
<b>Osnovna plošča GPL</b> 	<b>Skupina: 1227</b>			
	Normal M8 80 x 30 x 3	50	107501	
	Normal M10 80 x 30 x 3	50	138361	
	Normal 2G M8/M10 80 x 30 x 3	100	113016	
	Stabil M10 120 x 40 x 4	50	138343	
	Stabil M12 120 x 40 x 4	50	107556	
	Stabil M16 120 x 40 x 5	50	138352	
	Stabil R 1/2" 120 x 40 x 5	50	138529	
	Stabil R 3/4" 120 x 40 x 5	50	138538	
	Stabil R 1" 120 x 40 x 5	50	107592	
	<b>Osnovna plošča GPL F 80 Stabil</b> 	<b>Skupina: 1227</b>		
		GPL F 80 ST-1/2"	25	451280
GPL F 80 ST-3/4"		25	451281	
GPL F 80 ST-1"		25	451282	

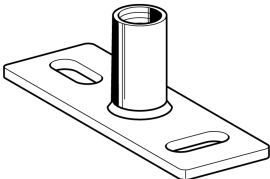
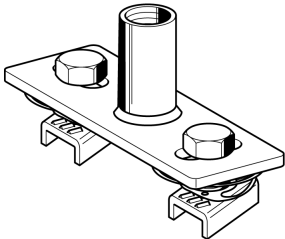
Produkt	Artikel	Pakirano	Artikel-št.
<b>Osnovna plošča GPL Siaqua</b> 	<b>Skupina: 1227</b>		
	GPL M16 120 x 40 x 4	1	666666
	GPL 1/2" 120 x 40 x 4	1	666668
	GPL 1/2" Stabil 120 x 40 x 8	1	600952
<b>Adapter za fiksno točko FPA</b> 	<b>Skupina: 1227</b>		
	M16	1	602321
	1/2"	1	602401
	1/2" Stabil	1	600953

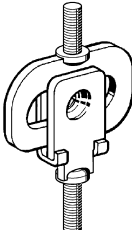
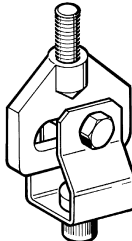
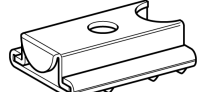
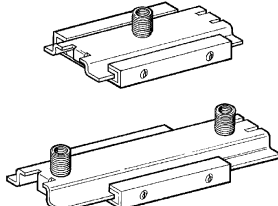

Produkt	Artikel	Pakirano	Artikel-št.
<b>Element drsni GLE LC</b> 	<b>Skupina: 1343</b>		
	LC-A 22	100	151069
	LC-I	100	151078
<b>Element drsni GLE J</b> 	<b>Skupina: 1343</b>		
	J 8 M8	25	126852
	J 10 M10	25	126861
	J 12 M12	25	126870
	J 16 M16	25	126889
<b>Drsnik GS 1G</b> 	<b>Skupina: 1336</b>		
	1G M10	25	198834
<b>Drsnik GS 2G</b> 	<b>Skupina: 1336</b>		
	2G	25	126755
	2G2	25	126764

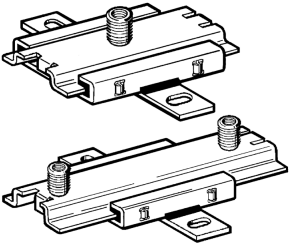
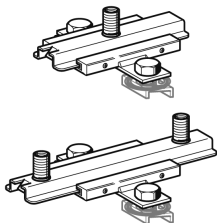
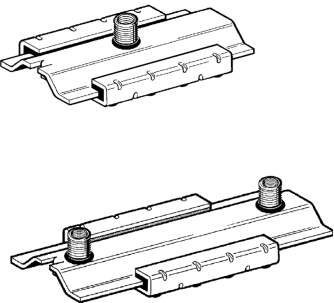
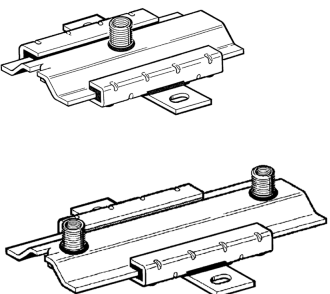
Produkt	Artikel	Pakirano	Artikel-št.
<b>Drsnik GS 2G-PL</b> 	<b>Skupina: 1336</b>		
	2G-PL	25	127127
	2G2-PL	25	127136
<b>Drsnik GS CC - 2G-PL</b> 	<b>Skupina: 1336</b>		
	CC - 2G-PL	25	191711
	CC - 2G2-PL	25	191729
<b>Drsnik GS H3G</b> 	<b>Skupina: 1336</b>		
	H3G	10	149295
	H3G2	10	126700
<b>Drsnik GS H3G-PL</b> 	<b>Skupina: 1336</b>		
	H3G-PL	10	149301
	H3G2-PL	10	126658

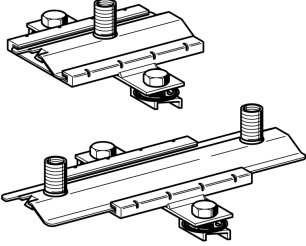
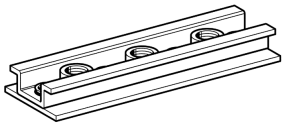

Produkt	Artikel	Pakirano	Artikel-št.
<b>Drsnik GS CC - H3G-PL</b>	<b>Skupina: 1336</b>		
	CC - H3G-PL	10	191747
	CC - H3G2-PL	10	191738
			
<b>Drsnik GS 41</b>	<b>Skupina: 1336</b>		
	41 - M10	10	190658
			

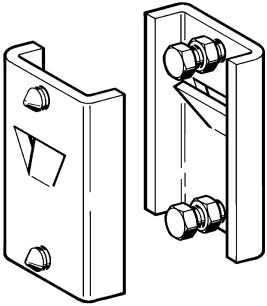
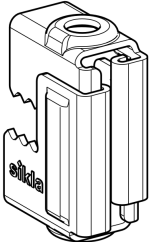
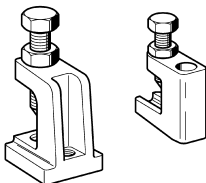
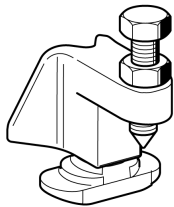
Produkt	Artikel	Pakirano	Artikel-št.
<b>Konzola objemna SKL</b> 	<b>Skupina: 1350</b>		
	SKL	5	145671
<b>Spona za nosilec TCS F (VdS/FM)</b> 	<b>Skupina: 1337</b>		
	TCS F VdS/FM	50	116488
<b>Spona za nosilec TCS</b> 	<b>Skupina: 1337</b>		
	TCS 0 LC	50	156648
	TCS 0 M8/M8	50	178283
	TCS 0 M8/M10	50	174206
	TCS 1 M10/M8	50	116770
	TCS 1 M10/M10	50	116150
	TCS 1 M10/M12	50	167332
	TCS 2 M12/M12	25	174224
	TCS 2 M12/M16	25	174215
<b>Spona za nosilec TCS 41</b> 	<b>Skupina: 1337</b>		
	TCS 41	50	110004

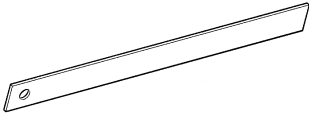
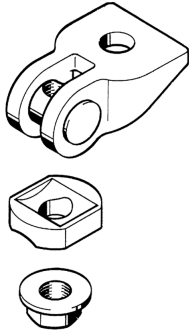
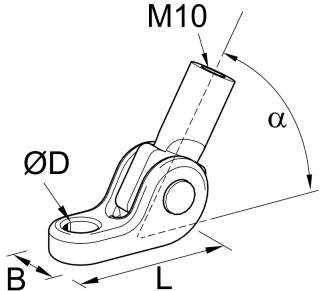
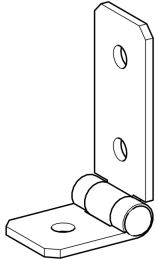

Produkt	Artikel	Pakirano	Artikel-št.
<b>Plošča varovalna SL VdS</b> 	<b>Skupina: 1338</b>		
	SL 1 fi 11mm	50	116798
	SL 2 fi 13mm	50	116804
	SL 3 fi 17mm	50	116813
<b>Zglob univerzalni UG</b> 	<b>Skupina: 1342</b>		
	UG M8	50	198636
	UG M10	50	198643
	UG M12	25	158075
	UG M16	25	158084
	UG FP M12	25	158093
	UG FP M16	25	158109
<b>Zglob SG</b> 	<b>Skupina: 1342</b>		
	SG M10-11	25	115044
	SG M10-13	25	115045
	SG M10-17	25	115046
<b>Zglob JOI S</b> 	<b>Skupina: 1342</b>		
	JOI S	50	116577

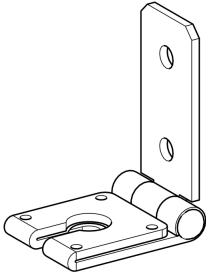
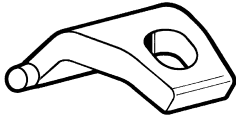
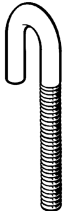
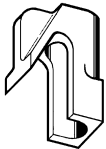
Produkt	Artikel	Pakirano	Artikel-št.
<b>Zglob JOI R</b> 	<b>Skupina: 1342</b>		
	20	50	116576
	23	50	116809
<b>Vpenjalni nastavek P</b> 	<b>Skupina: 1331</b>		
	P 1	50	116196
	M12	20	114880
	M16	20	114881
	M12 AU	20	115034
	M16 AU	20	115035
<b>Kljuka navojna GH</b> 	<b>Skupina: 1367</b>		
	M8 x 75	100	101587
	M8 x 115	100	101596
	M10 x 150	50	101602
<b>Kljuka vpenjalna SP</b> 	<b>Skupina: 1331</b>		
	SP	50	106777

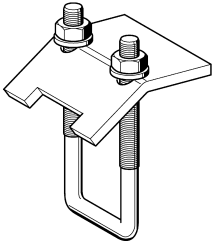
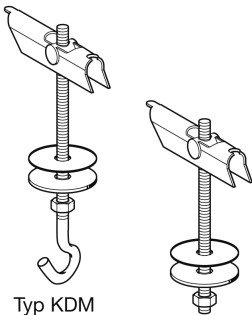
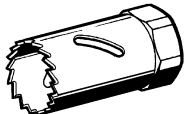
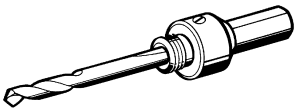

Produkt	Artikel	Pakirano	Artikel-št.
<b>Streme vpenjalno SB 41</b> 	<b>Skupina: 1331</b>		
	41 - M8	20	192566
	41 - M10	20	183620
	41 D - M10	20	191657
<b>Vložek obračalni KD</b>  <p>Typ KDM</p>	<b>Skupina: 1427</b>		
	KD M 6 x 130 V	50	402286
	M8 x 100	100	113810
	M8 x 200	50	125569
	TD10 x 100	100	126065
	TD10 x 200	50	125578
<b>Žaga luknjarica LS</b> 	<b>Skupina: 8139</b>		
	LS 22	1	133144
	LS 25	1	133135
<b>Nastavek za žago luknjarico ZBT</b> 	<b>Skupina: 8139</b>		
	AS-ZB 1	1	133126

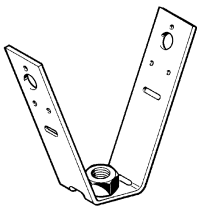
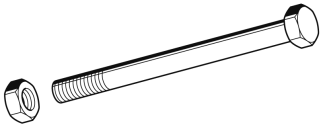
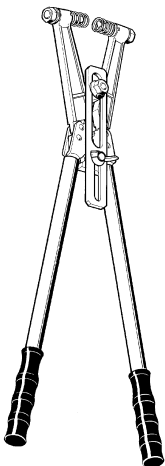

Produkt	Artikel	Pakirano	Artikel-št.
<b>Centrirni sveder ZB</b> 	<b>Skupina: 8139</b>		
	ZB	1	133117
<b>Obešalo trapezno TRH</b> 	<b>Skupina: 1428</b>		
	M8	100	125693
	M10	100	125806
	RM 8	100	125675
	RM 10	100	125684
	MS	100	151564
<b>Vijak matični za trapez MSR</b> 	<b>Skupina: 1428</b>		
	M8	100	406408
<b>Klešče za luknjanje LOT</b> 	<b>Skupina: 8140</b>		
	LOT 3	1	171296



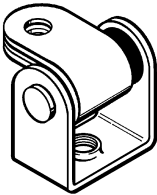
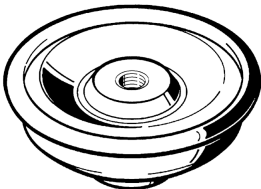
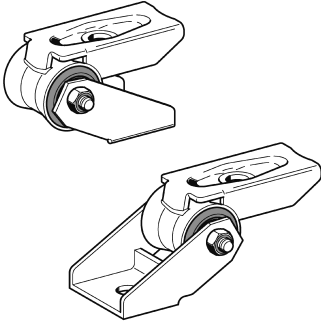
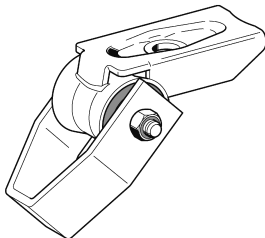



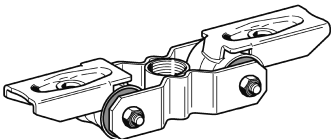
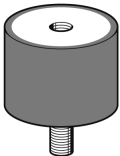
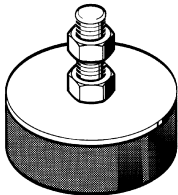

Produkt	Artikel	Pakirano	Artikel-št.
<b>Zvočni dušilec SDE 0</b> 	<b>Skupina: 1610</b>		
	SDE 0 - M8	100	105068
	SDE 0 - M10	100	105077
	SDE 0 - 0H	100	105059
<b>Zvočni dušilec SDE 1</b> 	<b>Skupina: 1612</b>		
	SDE 1 - M10	25	162735
	SDE 1 - 3G	25	136989
<b>Zvočni dušilec SDE 2 – SBV/SBZ</b> 	<b>Skupina: 1612</b>		
	SDE 2 - SBV	10	161406
	SDE 2 - SBZ	10	161062
<b>Zvočni dušilec SDE 2 - UG 16</b> 	<b>Skupina: 1612</b>		
	SDE 2 - UG 16	10	161053



Produkt	Artikel	Pakirano	Artikel-št.
<b>Zvočni dušilec SDE 2 - FP 1</b>	<b>Skupina: 1612</b>		
	SDE 2 - FP 1	10	161071
	<b>Skupina: 1399</b>		
	AKE 41 AG/IG M8	25	193983
	AKE 41 AG/IG M10	25	404710
	AKE 41 AG/AG M8	25	404711
	AKE 41 AG/AG M10	25	404712
	<b>Skupina: 1399</b>		
	GMT M12	1	117090
	<b>Skupina: 1294</b>		
	STD 1      25 x 3,0	30	146502
	STD 2      30 x 3,0	30	146511
	STD 3      40 x 4,0	30	146520
	STD 4      50 x 5,0	30	146539
	STD 5      70 x 6,0	30	146548

Produkt	Artikel	Pakirano	Artikel-št.
<b>Profilna guma SAL EPDM sk</b>	<b>Skupina: 1294</b>		
	30 x 1,0	20	188075
	40 x 1,0	20	188084
	50 x 1,0	20	188093
	60 x 1,0	20	188102
	70 x 1,0	20	188111
	80 x 1,0	20	800285
<b>Profilna guma SAL Silikon</b>	<b>Skupina: 1292</b>		
	STD 1 SIL 25 x 3,0	30	145644
	STD 2 SIL 30 x 3,0	30	145653
	STD 3 SIL 40 x 4,0	30	145662
	STD 4 SIL 50 x 5,0	30	146557
<b>Profilna guma SAL Silikon sk</b>	<b>Skupina: 1292</b>		
	30 x 1,0	10	404700
	40 x 1,0	10	404701
	50 x 1,0	10	404702
	60 x 1,0	10	404703
<b>Trak samolepilni iz penaste gume MSK</b>	<b>Skupina: 1293</b>		
	20 x 3,0	10	137616
	20 x 4,0	10	137412
	20 x 6,0	10	143590
	25 x 3,0	10	137722
	25 x 4,0	10	136563
	30 x 3,0	10	137607
	30 x 4,0	10	401728
	40 x 4,0	10	401729



Produkt

Artikel

Pakirano

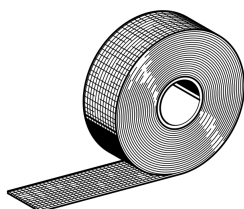

Artikel-št.

**Trak iz steklenih vlaken GSK**

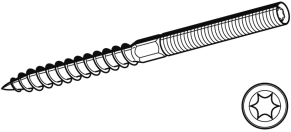

**Skupina: 1291**

30 x 2	10	114865
40 x 2	10	114866
50 x 2	10	114867
60 x 2	10	114868
70 x 2	10	114869
80 x 2	10	800284

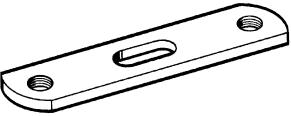
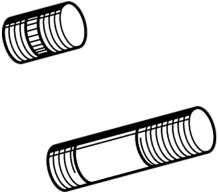
Produkt	Artikel	Pakirano	Artikel-št.	
<b>Vijak hanger brez vezi BSCR</b> 	<b>Skupina: 1315</b>			
	M8/60 mm	100	160849	
	M8/80 mm	100	124443	
	M8/90 mm	100	404491	
	M8/100 mm	100	124610	
	M8/120 mm	100	124595	
	M8/140 mm	50	124629	
	M8/160 mm	50	124601	
	M8/180 mm	50	404374	
	M10/60 mm	100	153469	
	M10/80 mm	100	124452	
	M10/100 mm	100	129554	
	M10/120 mm	50	124461	
	M10/140 mm	50	124470	
	M10/160 mm	50	404375	
	M10/180 mm	50	131522	
	<b>Nastavek za vijak hanger ANT BIT</b> 	<b>Skupina: 8101</b>		
		M8	1	121343
		M10	1	121334
<b>Ploščica dvojna držalna DHP M8</b> 	<b>Skupina: 1329</b>			
	65 mm	50	124850	
	85 mm	50	124869	
	105 mm	50	124878	
	125 mm	50	411772	
<b>Spojnik dvojni navojni BOL M8</b> 	<b>Skupina: 1318</b>			
	12 mm	100	124586	
	30 mm	100	124887	
	40 mm	100	124896	
	50 mm	100	153681	
	75 mm	100	112913	

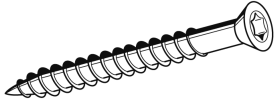
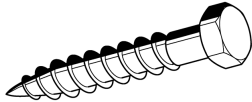
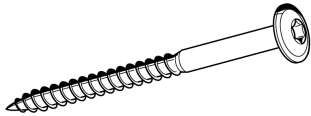

Produkt	Artikel	Pakirano	Artikel-št.
<b>Vijak SNK TG</b> 	<b>Skupina: 1376</b>		
	4 x 40	500	410637
	4 x 50	500	410638
	5 x 50	200	410639
	5 x 60	200	410640
	5 x 70	200	410641
	6 x 50	200	410642
	6 x 60	200	410643
	6 x 70	200	410644
	6 x 80	200	410645
<b>Vijak šestrobi lesni SKH</b> 	<b>Skupina: 1370</b>		
	6/50	200	405382
	6/60	200	405355
	6/70	100	166997
	6/80	100	405373
	8/50	100	156596
	8/60	100	156602
	8/70	100	167013
	8/80	100	156611
	8/100	100	125107
	8/120	100	405409
	10/70	100	156620
	10/80	100	405391
	10/100	100	153663
	10/120	100	405400
<b>Vijak lesni FLAH</b> 	<b>Skupina: 1369</b>		
	8/40	50	110804
	8/60	50	110805
	8/80	50	110806
	8/100 A	50	410631
	8/120 A	50	410632
	8/140 A	50	410633
	8/160 A	50	410634
	10/70	50	110807
	10/100	50	110809

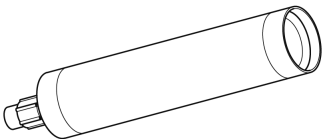
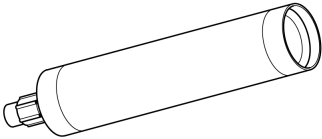
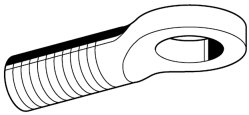
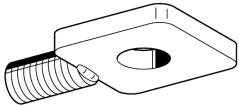
Produkt	Artikel	Pakirano	Artikel-št.
<b>Masa za sidranje VME plus</b> 	<b>Skupina: 1409</b>		
	VME plus 440-M *	1	407260
	Statikmischer ANT VM-X HP	1	804293
<b>Masa za sidranje VMH</b> 	<b>Skupina: 1409</b>		
	VMH 280-M	1	805227
	Statikmischer ANT VM-X HP	1	804293
<b>Vijak očesni SCR</b> 	<b>Skupina: 1303</b>		
	M8	100	102418
	M10	100	102427
<b>Vijak ploščični SCR</b> 	<b>Skupina: 1303</b>		
	M8 x 20	100	102436
	M8 x 40	100	102445
	M10 x 20	100	102454
	M10 x 40	50	102463



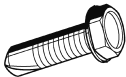
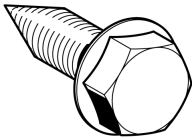
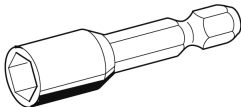

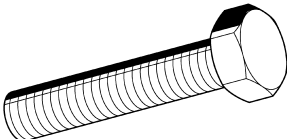
Produkt	Artikel	Pakirano	Artikel-št.
<b>Del cevni vpenjali SCB</b>  	<b>Skupina: 1301</b>		
	M8	100	124221
	M10	100	124203
	M12	100	150916
<b>Vijak z vrtalno konico SKB</b>  	<b>Skupina: 1370</b>		
	4,2 x 13	1000	413140
	4,2 x 19	1000	413158
	4,2 x 25	1000	413159
	6,3 x 25	500	413149
<b>Vijak samorezni SCR L</b>  	<b>Skupina: 1370</b>		
	SCR L-14	1000	110577
	SCR L-18	1000	110877
<b>Nastavek magnetni MN</b>  	<b>Skupina: 8100</b>		
	SW 1/4"	1	412959
	SW 7	1	412960
	SW 10	1	412969
	SW 13	1	412978

Produkt	Artikel	Pakirano	Artikel-št.
	<b>Skupina: 1370</b>		
	M8/16	100	125161
	M8/20	100	138459
	M8/25	100	138431
	M8/30	100	138574
	M8/35	100	404788
	M8/40	100	138440
	M8/60	100	114705
	M8/70	100	406462
	M8/80	100	114714
	M8/100	100	138608
	M8/110	100	124975
	M10/16	100	406480
	M10/20	100	138617
	M10/25	100	138468
	M10/30	100	138626
	M10/35	100	404815
	M10/40	100	114158
	M10/45	100	406489
	M10/60	100	138635
	M10/70	100	406498
	M10/80	50	114723
	M10/100	50	114732
	M10/120	50	138644
	M12/16	100	406661
	M12/20	100	138653
	M12/25	100	138662
	M12/30	100	138477
	M12/35	100	404419
	M12/40	50	138671
	M12/45	100	406516
	M12/55	100	413167
M12/60	50	138680	
M12/70	50	405328	
M12/80	50	138705	
M12/100	50	138714	
M12/120	50	114750	
M16/25	50	138723	
M16/30	50	138732	
M16/35	50	404428	
M16/40	50	406552	
M16/45	50	138741	
M16/50	50	404446	
M16/60	50	138556	
M16/80	25	138750	
M16/100	25	138769	
M16/120	25	114778	
M20/60	25	406561	
M24/70	25	404482	

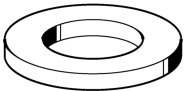
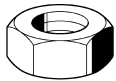
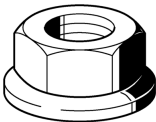

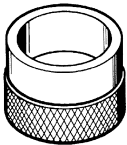
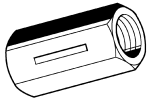
Produkt	Artikel	Pakirano	Artikel-št.	
<b>Podložka US</b>  	<b>Skupina: 1372</b>			
	5/125	100	125301	
	6/125	100	125310	
	8/125	100	125329	
	10/125	100	137564	
	12/125	100	114246	
	16/125	100	114255	
	8/9021	100	137883	
	8/9022	200	404716	
	8/40	100	105581	
	8/45	100	105624	
	10/9021	100	125365	
	10/40	100	105590	
	10/45	100	105633	
	12/30	100	156462	
	12/40	100	105606	
	16/40	100	105615	
	16/9021	100	406570	
	20/125	200	432014	
	24/125	200	432015	
	<b>Matica šestroba NT</b>  	<b>Skupina: 1371</b>		
		M5	100	125338
		M6	100	125347
		M8	100	125356
M10		100	137546	
M12		100	114228	
M16		100	114237	
M20		50	404383	
M24		50	404392	
<b>Matica prirobna NT FLA</b>  		<b>Skupina: 1374</b>		
		M8	50	158729
	M10	25	158738	
	M12	25	158747	
	M16	10	160654	

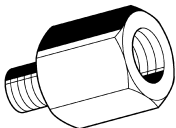
Produkt	Artikel	Pakirano	Artikel-št.
<b>Matica narebričena N</b> 	<b>Skupina: 1116</b>		
	M8	50	102232
	M10 FM	50	102241
	M10	25	102250
	M12	25	102269
	M16	10	102278
<b>Podaljšek navojni AD IG/IG</b> 	<b>Skupina: 1332</b>		
	M8 x 25	100	124920
	M10 x 30	100	124939
	M12 x 35	50	124948
	M16 x 40	50	124957
<b>Podaljšek okrogli AD RD</b> 	<b>Skupina: 1332</b>		
	M8 x 30	100	157232
	M10 x 30	100	157250
	M12 x 35	50	157278
	M16 x 45	50	157296
	M16 x 100	20	191108
	M16 x 150	20	191117
	1/2" x 45	20	191126
<b>Kos prehodni AD IG/AG</b> 	<b>Skupina: 1313</b>		
	8/10	50	113670
	10/8	50	113689
	10/16	50	113698
	16/10	50	113704



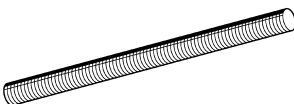
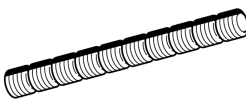
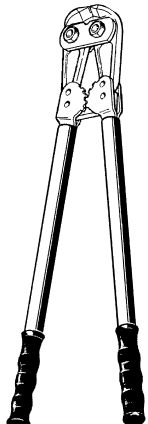

Produkt	Artikel	Pakirano	Artikel-št.
<b>Navojni zatič GST 8.8</b>  	<b>Skupina: 1316</b>		
	M10/40	100	116782
	M10/100	100	116781
<b>Navojni zatič PNS</b>  	<b>Skupina: 2109</b>		
	M8 x 90	100	160308
	M8 x 140	100	160317
	M8 x 190	100	160326
	M8 x 290	100	160335
	M8            1 m	1	157755
	M10 x 90	100	160344
	M10 x 140	100	160353
	M10 x 190	100	160362
	M10 x 290	100	160371
	M10            1 m	1	157773
<b>Klešče za PNS navojni zatič PBC</b>  	<b>Skupina: 2107</b>		
	PBC	1	155683

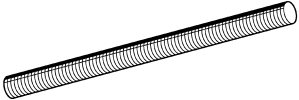
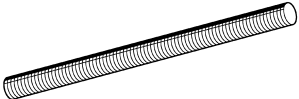
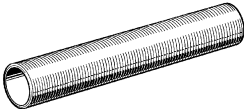
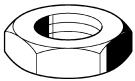

Produkt	Artikel	Pakirano	Artikel-št.	
<b>Navojna palica GST 4.8</b> 	<b>Skupina: 1317</b>			
	M8 1 m	25	124559	
	M10 1 m	25	124568	
	M12 1 m	25	143192	
	M16 1 m	10	110817	
	M20 1 m	10	501582	
	M24 1 m	5	501581	
	M8 2 m	50	142696	
	M10 2 m	50	142702	
	M12 2 m	20	142711	
	M16 2 m	20	142720	
	M8 3 m	30	142739	
	M10 3 m	30	142748	
	M12 3 m	30	142757	
	M16 3 m	15	142766	
	<b>Navojna palica BSK 5.8</b> 	<b>Skupina: 1317</b>		
		M10 x 3000 3 m	3	415813
		M12 x 3000 3 m	3	415814
		M16 x 3000 3 m	3	415815
<b>Navojna cev GR</b> 	<b>Skupina: 1310</b>			
	G 1/2"	2	151102	
	G 3/4"	2	151111	
	G 1"	2	151120	
<b>Protimatica NT G</b> 	<b>Skupina: 1310</b>			
	G 1/2"	25	157092	
	G 3/4"	25	157108	
	G 1"	25	157117	

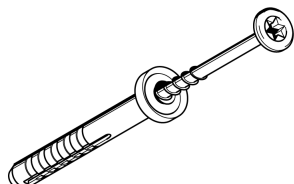
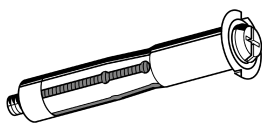
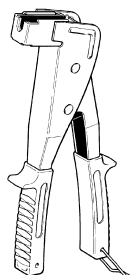
Produkt	Artikel	Pakirano	Artikel-št.
<b>Vložek zidni ANA</b> 	<b>Skupina: 1415</b>		
	6 x 30	100	402430
	8 x 40	100	402431
	10 x 50	50	402432
	12 x 60	25	402433
	14 x 70	20	402434
<b>Vložek z žebljem ANH</b> 	<b>Skupina: 1418</b>		
	5 x 35	100	402380
	5 x 45	100	402381
	6 x 35	100	402382
	6 x 60	100	402383
	6 x 70	100	402384
	8 x 60	100	402385
	8 x 80	100	402386
	8 x 100	100	402387
8 x 120	100	402388	
<b>Vložek za votle stene ANC-M</b> 	<b>Skupina: 1416</b>		
	M4/12 <sup>1)</sup>	100	402400
	M5/16 <sup>1)</sup>	100	402401
	M5/32 <sup>1)</sup>	100	402402
	M6/16 <sup>1)</sup>	100	402403
	M6/32 <sup>1)</sup>	100	402404
	M6/49	100	402407
	M8/18 <sup>1)</sup>	100	114315
	M8/32 <sup>1)</sup>	100	114316
	M8/45	100	402408
<b>Klešče montažne za ANC-M MZ</b> 	<b>Skupina: 8106</b>		
	M4 - M8 <sup>1)</sup>	1	408578



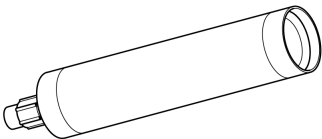
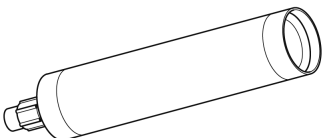
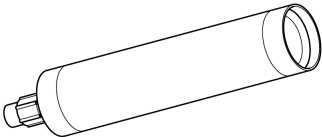

Produkt	Artikel	Pakirano	Artikel-št.
<b>Masa za sidranje VMU plus</b>	<b>Skupina: 1409</b>		
	VMU plus 280	1	114176
	Statikmischer ANT VM-X	1	190829
			
<b>Masa za sidranje VMZ</b>	<b>Skupina: 1409</b>		
	VMZ 280	1	501634
	Statikmischer ANT VM-X	1	190829
			
<b>Masa za sidranje POLY SF</b>	<b>Skupina: 1409</b>		
	VM Poly SF 300	1	407261
	Statikmischer ANT VM-X	1	190829
			
<b>Pribor VMZ / VMU plus</b>	<b>Skupina: 8106</b>		
	Ščetka žična VM-STB (RB 10) M8	1	190838
	Ščetka žična VM-STB (RB 12) M10	1	190847
	Ščetka žična VM-STB (RB 14) M12	1	190856
	Ščetka žična VM-STB (RB 18) M16	1	190865
	Izpihalo ANT VM-AP 360	1	190883
	Podaljšek za mešanje VM-XE 10/200	12	117520

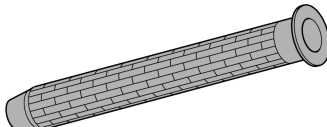
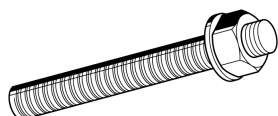
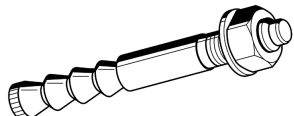
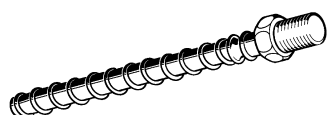

Produkt	Artikel	Pakirano	Artikel-št.
 <p><b>Tulec sitasti PVC VMU - SH</b></p>	<b>Skupina: 1410</b>		
	VM-SH 12 x 80 M8	10	116925
	VM-SH 16 x 85 M8 - M10	10	116926
	VM-SH 16 x 130 M8 - M10	10	116927
	VM-SH 20 x 85 M12 - M16	10	116928
	VM-SH 20 x 130 M12 - M16	10	116929
 <p><b>Vijak sidrni VMU-A</b></p>	<b>Skupina: 1409</b>		
	VMU-A 10 x 130	10	110447
	VMU-A 10 x 150	10	110448
	VMU-A 12 x 120	10	110449
	VMU-A 12 x 155	10	110450
 <p><b>Vijak sidrni VMZ-A</b></p>	<b>Skupina: 1409</b>		
	VMZ-A 60 M10-10/85	10	190739
	VMZ-A 60 M10-30/105 <sup>1)</sup>	10	190748
	VMZ-A 60 M10-60/135 <sup>1)</sup>	10	190757
	VMZ-A 80 M12-10/110	10	190766
	VMZ-A 80 M12-25/125	10	190775
	VMZ-A 80 M12-50/150 <sup>1)</sup>	10	190784
 <p><b>Vijačno sidro TSM-ST</b></p>	<b>Skupina: 1402</b>		
	6 x 35 K *	100	115030
	6 x 55 <sup>1)</sup>	100	115725
	6 x 75 <sup>1)</sup>	100	115726
	6 x 95 <sup>1)</sup>	100	115727
	6 x 135 <sup>1)</sup>	100	117835
	6 x 155 <sup>1)</sup>	100	117836
	6 x 175	100	117837
	6 x 195 <sup>1)</sup>	100	117838

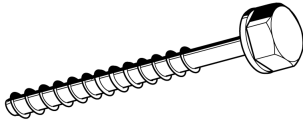
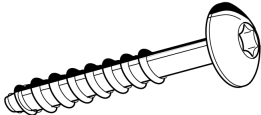
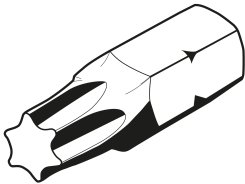
Produkt	Artikel	Pakirano	Artikel-št.
<b>Vijačno sidro TSM-S</b> 	<b>Skupina: 1407</b>		
	6 x 40 *	100	115737
	6 x 50	100	115720
	6 x 60	100	115723
	6 x 80	100	115738
	6 x 100	100	115739
	8 x 50	50	115731
	8 x 60	50	115732
	8 x 70	50	115734
	8 x 80	50	115735
	8 x 90	50	115736
	8 x 100	50	115728
	8 x 120	50	115729
	8 x 140	50	115730
	10 x 60	50	115740
	10 x 70	50	115741
	10 x 80	50	115743
	10 x 90	50	115744
	10 x 100	50	115745
	10 x 140	50	115746
	12 x 110	25	115747
	12 x 130	25	115748
12 x 150	25	115749	
<b>Vijačno sidro TSM LP VZ 30</b> 	<b>Skupina: 1405</b>		
	6 x 40	100	115026
	6 x 60	100	115722
	LPS 6 x 40	100	116691
	LPS 6 x 60	100	116692
<b>Nastavek BIT Torx 30</b> 	<b>Skupina: 8107</b>		
	Torx 30	1	403447

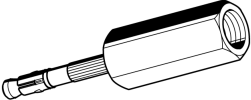
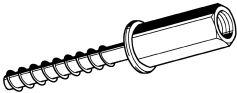
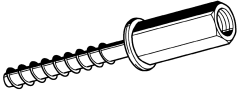

Produkt	Artikel	Pakirano	Artikel-št.
<b>Sidro udarno AN</b>	<b>Skupina: 1406</b>		
	AN N M8/M10 6 x 25	100	112152
	AN N M8/M10 6 x 30	100	117561
			
<b>Vijačno sidro TSM-IM</b>	<b>Skupina: 1402</b>		
	6 x 35 K * M8/M10	50	115028
	6 x 55 M8/M10	50	115721
			
<b>Vijačno sidro TFF en kos</b>	<b>Skupina: 1402</b>		
	6 x 35 M8/M10	50	411692
	6 x 55 M8/M10	50	411693
			





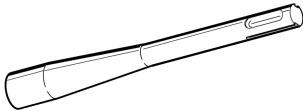
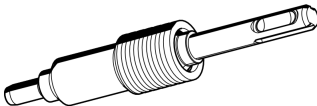
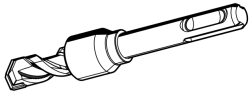

Produkt	Artikel	Pakirano	Artikel-št.	
<b>Orodje za nameščanje sidro BWS</b>	<b>Skupina: 8103</b>			
	BWS	1	452004	
	<b>Skupina: 1401</b>			
	ES M8 x 25	100	116618	
	ES M8 x 30	100	110467	
	ES M8 x 40	100	110468	
	ES M10 x 25	50	116619	
	ES M10 x 30	50	110506	
	ES M10 x 40	50	110469	
	ES M12 x 25 <sup>1)</sup>	50	116620	
	ES M12 x 50	50	110470	
	ES M16 x 65	25	110471	
<b>Razcepnik /Sveder za sidra ASW</b>	<b>Skupina: 8103</b>			
	ASW M8 x 25	1	116636	
	ASW M8 x 30	1	116637	
	ASW M8 x 40	1	116638	
	ASW M10 x 25	1	116639	
	ASW M10 x 30	1	116640	
	ASW M10 x 40	1	116641	
	ANT BB 10 x 25	1	116666	
	ANT BB 10 x 30	1	116667	
	ANT BB 10 x 40	1	116668	
	ANT BB 12 x 25	1	116669	
	ANT BB 12 x 30	1	116670	
	ANT BB 12 x 40	1	116671	
	 			

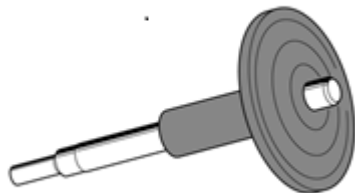
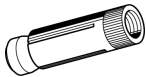
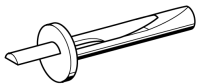
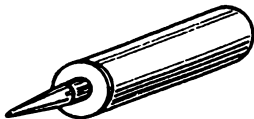

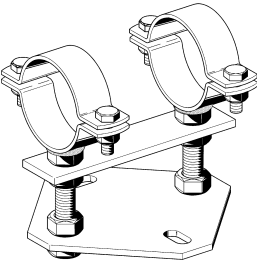
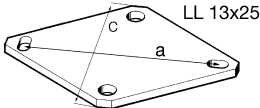
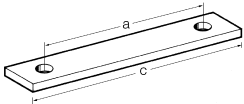
Produkt	Artikel	Pakirano	Artikel-št.
	<b>Skupina: 8103</b>		
	M8 x 25	1	117514
	M8 x 30	1	111834
	M8 x 40	1	111835
	M10 x 25	1	117515
	M10 x 30	1	111836
	M10 x 40	1	111837
	M12 x 25	1	117516
	M12 x 50	1	111838
	M16 x 65	1	111839
	<b>Skupina: 1412</b>		
	AN Easy M8 <sup>1)</sup>	50	110463
	AN Easy M10	50	110465
	AN Easy M12 <sup>1)</sup>	25	110466
	<b>Skupina: 1406</b>		
	PN 27 N6 x 35	100	196298
	<b>Skupina: 7401</b>		
	beli	20	135863
	prozoren	20	139733

Produkt	Artikel	Pakirano	Artikel-št.
<b>Sklop fiksne točke FPK</b> 	<b>Skupina: 1380</b>		
	FP-K4/1	1	407885
<b>Plošča pritrjevalna FPKNO</b> 	<b>Skupina: 1381</b>		
	FP-K3/16	10	404140
	FP-K4/16	10	404158
	FP-K5/16	5	406976
<b>Plošča ravna FPFL-ST</b> 	<b>Skupina: 1381</b>		
	FP-FL-ST/4	10	406381
	FP-FL-ST/5	10	406985
<b>Objemka fikse točke FS</b> 	<b>Skupina: 1380</b>		
	21,3	1	159979
	26,9	1	159988
	33,7	1	159997
	42,4	1	160007
	48,3	1	160025
	60,3	1	160043
	76,1	1	160052
	88,9	1	160061
	114	1	160089
	139	1	160104
	168	1	160122
	219	1	160131
	274	1	160140

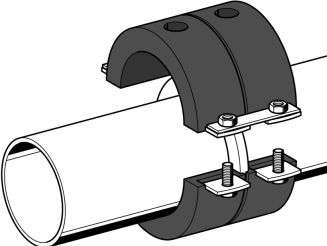
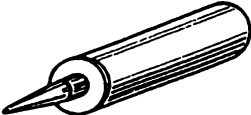
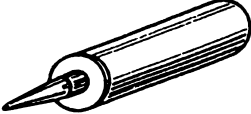
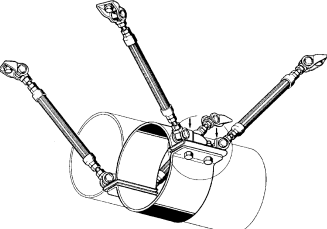

Produkt	Artikel	Pakirano	Artikel-št.
<b>Objemka hladilna za fiksno točko FKS</b>	<b>Skupina: 1382</b>		
	76,1	1	190271
	88,9	1	190289
	114,3	1	190307
	139,7	1	190325
	168,3	1	190343
	219,1	1	190352
	273	1	190379
	323,9	1	190388
<b>Tesnilna masa DP 30/45</b>	<b>Skupina: 1252</b>		
	30/45	1	146283
<b>Tesnilna masa DP S-1035</b>	<b>Skupina: 1252</b>		
	S-1035	1	407600
<b>Sklop povezovalni VP A/B</b>	<b>Skupina: 1380</b>		
4 x 	A/B-M12	1	160663
	A/B-M16	1	160672
	A/B-1/2"	1	160681
	A/B-3/4"	1	160690
	A/B-1"	1	160706

Produkt

Artikel

Pakirano

Artikel-št.

**Sklop povezovalni VP SDE 2**

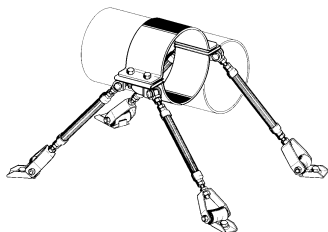

4 x



**Skupina: 1380**

Artikel	Pakirano	Artikel-št.
SDE 2 A/B-M16	1	178166
SDE 2 A/B-1/2"	1	178175
SDE 2 A/B-3/4"	1	178184
SDE 2 A/B-1"	1	178193

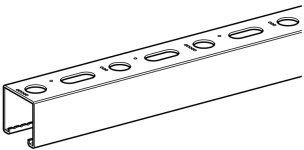
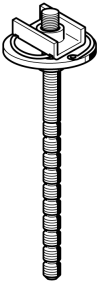
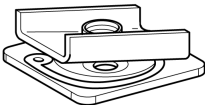

Produkt	Artikel	Pakirano	Artikel-št.
<b>Montažni profil MS 27 – 1,25</b> 	<b>Skupina: 2711</b>		
	27/15/1,25 2	20	110856
	27/25/1,25 2	20	110857
	27/25/1,25 6	36	110858
<b>Montažni komplet PBS CC 27</b> 	<b>Skupina: 2761</b>		
	M8 x 35	100	195888
	M8 x 75	100	195895
	M8 x 125	50	195901
	M8 x 175	50	195918
	M8 x 275	50	195925
<b>Blok PB 27</b> 	<b>Skupina: 2760</b>		
	M8	100	195932
	M10	100	117357
<b>Matica kljukasta NT CC 27</b> 	<b>Skupina: 2714</b>		
	CC 27-M6	100	195956
	CC 27-M8	100	195949
	CC 27-M10	100	117358

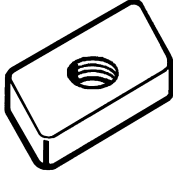
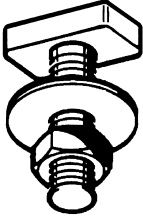
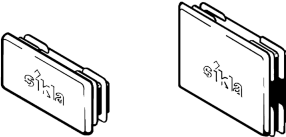
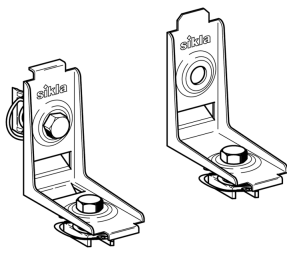
Produkt	Artikel	Pakirano	Artikel-št.
<b>Matica navojna NT 27</b> 	<b>Skupina: 2714</b>		
	27-M8	100	124382
	27-M10	100	181577
<b>Vijak s kljukasto glavo HM 27</b> 	<b>Skupina: 2715</b>		
	HM 27 M8 x 25/14	50	106485
	HM 27 M10 x 25/14	50	106500
<b>Zaključna kapica ADK 27</b> 	<b>Skupina: 2704</b>		
	27/15	100	193969
	27/25	100	111463
	27/37	100	110571
<b>Kotnik CN CC 27-90°</b> 	<b>Skupina: 2726</b>		
	CC 27-90°	50	195772
	CC 27-90° W	50	195789

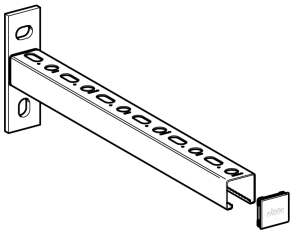
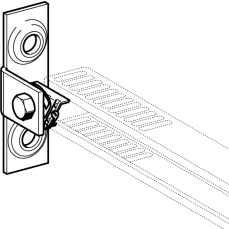
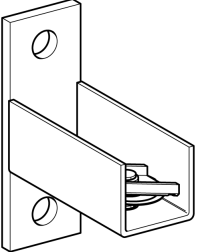
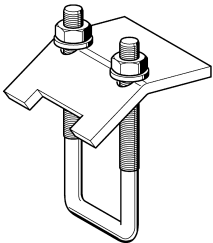

Produkt	Artikel	Pakirano	Artikel-št.	
<b>Konzola previsna AK 27 - 1,25</b>  	<b>Skupina: 2754</b>			
	27/25 - 200	25	112326	
	27/25 - 250	25	112327	
	27/25 - 300	25	112328	
	27/25 - 500	25	112329	
	27/25 - 700	1	112330	
	27/25 q - 300	25	112366	
	27/37 - 300	25	111458	
	27/37 - 500	25	111459	
	27/37 - 700	1	111460	
	27/37 - 800	1	111461	
	<b>Montažni komplet MOS 27</b>  	<b>Skupina: 2730</b>		
		MV 27	10	195871
	<b>Držalo MOF 27</b>  	<b>Skupina: 2753</b>		
MH 27		25	198858	
MV 27		25	198865	
<b>Streme vpenjalno SB 27</b>  	<b>Skupina: 2731</b>			
	27 - M8	20	195864	

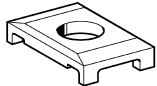
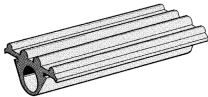
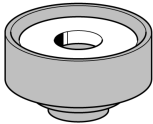
Produkt	Artikel	Pakirano	Artikel-št.
<b>Ozobje kljukasto HK 27</b>	<b>Skupina: 2727</b>		
	27/10	50	114422
			
<b>Profilna guma SAL 27</b>	<b>Skupina: 2710</b>		
	27	30	195963
	27/L100	-	195970
			
<b>Zvočni dušilec SDE 27</b>	<b>Skupina: 2712</b>		
	27	100	197973
			

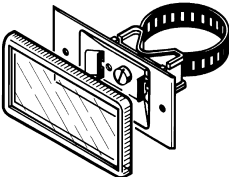
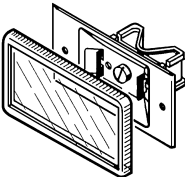
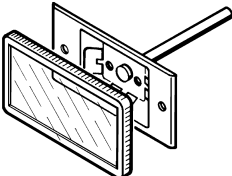
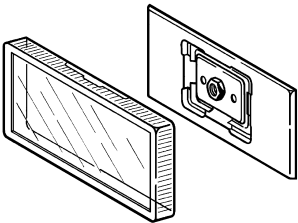

Produkt	Artikel	Pakirano	Artikel-št.
<b>Tablica z vpenjalnim trakom UNI M S</b> 	<b>Skupina: 6101</b>		
	Tablica 100/50 mm	25	127552
	Tablica A2 100/50 mm	25	127464
<b>Tablica brez vpenjanega traka UNI</b> 	<b>Skupina: 6101</b>		
	Tablica	25	127163
	Tablica A2	25	127491
<b>Tablica privarilna UNI</b> 	<b>Skupina: 6101</b>		
	Tablica privarilna UNI	25	127561
<b>Tablica privijalna SHT</b> 	<b>Skupina: 6101</b>		
	Tablica privijalna SHT	25	127570
	Tablica privijalna SHT A2	25	127473

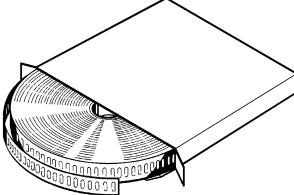
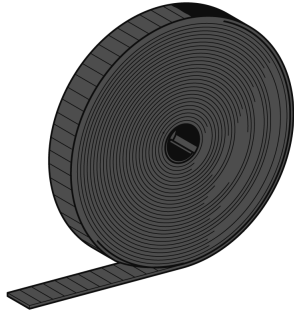
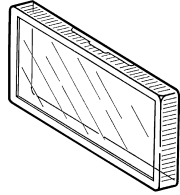
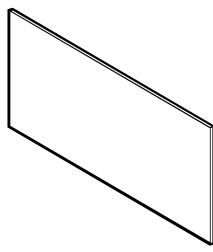
Produkt	Artikel	Pakirano	Artikel-št.
<b>Trak vpenjalni LOH ALU</b> 	<b>Skupina: 6112</b>		
	Trak vpenjalni alu	12	127598
	Trak vpenjalni A2	12	113005
<b>Trak ježek KBD</b> 	<b>Skupina: 6112</b>		
	20-25m	1	407004
<b>Pokrov plastični SHA</b> 	<b>Skupina: 6112</b>		
	SHA	25	127589
<b>Tablica barvna LOG</b> 	<b>Skupina: 2130</b>		
	rdeča - bela 100 x 50 x 1,5	50	127686
	modra - bela 100 x 50 x 1,5	50	127695
	zelena - bela 100 x 50 x 1,5	50	127701
	rumena - bela 100 x 50 x 1,5	50	127710
	črna - bela 100 x 50 x 1,5	50	127729
	siva - bela 100 x 50 x 1,5	50	127747
	bela - bela 100 x 50 x 1,5	50	127756
	lila - bela 100 x 50 x 1,5	50	410791
	rjava - bela 100 x 50 x 1,5	50	410800
	oranžna - bela 100 x 50 x 1,5	50	410809
	rumena - črna 100 x 50 x 1,5	50	410971
	bela - črna 100 x 50 x 1,5	50	410980







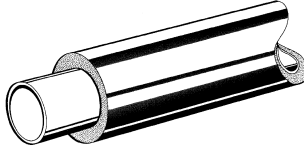

Produkt	Artikel	Pakirano	Artikel-št.	
	<b>Gruppe: 3701</b>			
	9 x 15	12 - 15	380	130239
	9 x 18	16 - 18	330	130248
	9 x 22	20 - 22	250	130257
	9 x 28	25 - 28	190	130266
	9 x 35	33 - 36	150	130275
	9 x 42	38 - 42	110	130284
	9 x 48	44 - 50	90	130293
	9 x 60	57 - 60	66	130318
	9 x 76	70 - 76	48	130734
	9 x 89	85 - 90	40	144148
	13 x 15	12 - 15	256	135809
	13 x 18	16 - 18	220	130336
	13 x 22	20 - 22	180	135818
	13 x 28	25 - 28	140	135827
	13 x 35	33 - 36	120	144218
	13 x 42	38 - 42	90	144236
	13 x 48	44 - 50	70	144254
	13 x 60	57 - 60	48	144272
	13 x 76	70 - 76	40	144290
	13 x 89	85 - 90	30	144430
	13 x 114	110 - 114	22	144412
	20 x 15	12 - 15	134	407320
	20 x 18	16 - 18	126	407321
	20 x 22	20 - 22	108	135784
	20 x 28	25 - 28	96	135836
	20 x 35	33 - 36	70	135845
	20 x 42	38 - 42	60	135793
	20 x 48	44 - 50	48	144360
	20 x 60	57 - 60	40	144388
	20 x 76	70 - 76	26	144403
	20 x 89	85 - 90	24	407327
20 x 114	110 - 114	14	407336	
25 x 15	12 - 15	90	407400	
25 x 18	16 - 18	90	407401	
25 x 22	20 - 22	70	407402	
25 x 28	25 - 28	66	407403	
25 x 35	33 - 36	56	407404	
25 x 42	38 - 42	48	407405	
25 x 48	44 - 50	40	407406	
25 x 60	57 - 60	30	407420	
25 x 76	70 - 76	24	407421	
25 x 89	85 - 90	16	407422	
25 x 114	110 - 114	12	407423	

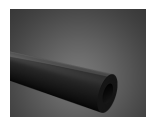

Produkt

Artikel

Pakirano

Artikel-št.

**Izolacijska plošča Kelon**

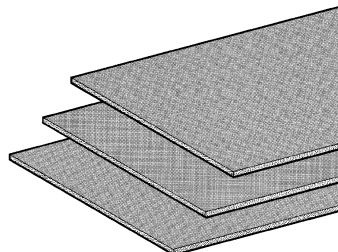

**Gruppe: 3707**

SHP 9		15	143280
SHP 18		8	143305

**Climaflex CFX Natur Easy**

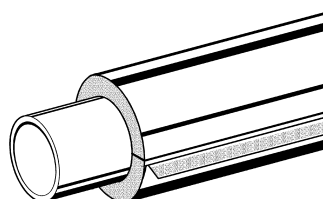

**Gruppe: 3705**

9 - 15	12 - 15	300	407345
9 - 18	16 - 18	300	407354
9 - 22	20 - 22	250	407363
9 - 28	25 - 28	190	407372
9 - 35	33 - 36	150	407381
13 - 15	12 - 15	200	161123
13 - 18	16 - 18	190	161132
13 - 22	20 - 22	160	161141
13 - 28	25 - 28	130	161150
13 - 35	33 - 36	102	161169
13 - 42	38 - 42	84	161178
13 - 48	44 - 50	70	161187
13 - 60	57 - 60	48	161196
20 - 22	20 - 22	108	409210
20 - 28	25 - 28	96	409211
20 - 35	33 - 36	70	409212
20 - 42	38 - 42	60	409213
20 - 48	44 - 50	48	409214
20 - 54	52 - 56	48	409215
20 - 60	57 - 60	40	409216

**Climaflex CFX Natur Easy koleno**

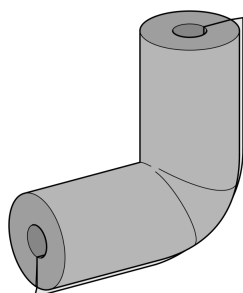

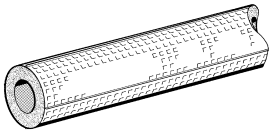
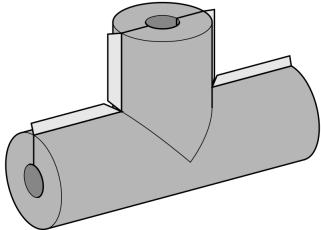
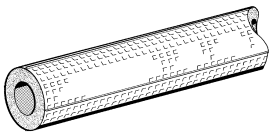

**Gruppe: 3706**

13 x 15		28	409265
13 x 18		25	409266
13 x 22		20	409267
13 x 28		18	409268
13 x 35		15	409269
13 x 42		12	409270

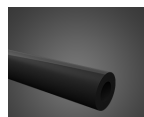
Produkt	Artikel	Pakirano	Artikel-št.	
<b>Climaflex CFX Basic Stabil</b> 	<b>Gruppe: 3710</b>			
	6 - 15	12 - 15	300	407230
	6 - 18	16 - 18	270	407231
	6 - 22	20 - 22	250	407232
	6 - 28	25 - 28	220	407233
	6 - 35	32 - 35	180	407234
<b>Climaflex CFX Natur Easy T-kos</b> 	<b>Gruppe: 3708</b>			
	13 x 15		30	409271
	13 x 18		25	409272
	13 x 22		20	409273
	13 x 28		15	409274
<b>Climaflex CFX Natur Stabil</b> 	<b>Gruppe: 3710</b>			
	4 - 15	12 - 15	200	407220
	4 - 22	20 - 22	160	407222
	4 - 35	33 - 36	110	407224
	9 - 15	12 - 15	120	161202
	9 - 18	16 - 18	120	161211
	9 - 22	20 - 22	100	161220
	9 - 28	25 - 28	90	161239
	9 - 35	33 - 36	60	161248
	9 - 42	38 - 42	48	407390
	13 - 15	12 - 15	100	161257
	13 - 18	16 - 18	96	161266
	13 - 22	20 - 22	80	161275
	13 - 28	25 - 28	64	161284
	13 - 35	33 - 36	48	161293
	13 - 42	38 - 42	40	407391
	20 - 15	12 - 15	58	407387
	20 - 18	16 - 18	56	407388
	20 - 22	20 - 22	48	407389
	20 - 28	25 - 28	40	407392
20 - 35	33 - 36	32	407393	
20 - 42	38 - 42	24	407394	
25 - 28	25 - 28	30	407413	
25 - 35	33 - 36	26	407414	
25 - 42	38 - 42	24	407415	

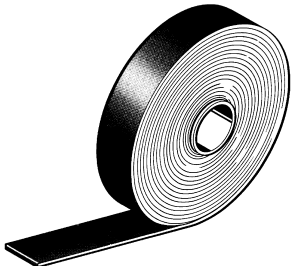

Produkt	Artikel	Pakirano	Artikel-št.
<p><b>Izolacijski trak CFX</b></p> 	<p><b>Gruppe: 3703</b> 50 x 3 S</p>	<p>6</p>	<p>402510</p>
<p><b>Lepilo CFX NMC-fix</b></p> 	<p><b>Gruppe: 3702</b> 250 ml 500 ml</p>	<p>1 1</p>	<p>404175 404176</p>
<p><b>Spojka Climaflex CFX</b></p> 	<p><b>Gruppe: 3200</b> CFX Clips 100 Stk.</p>	<p>1</p>	<p>407310</p>











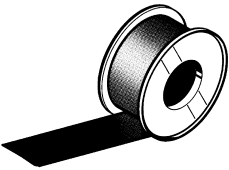
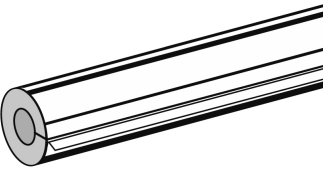
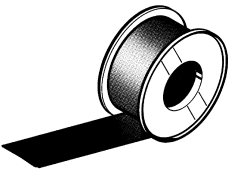

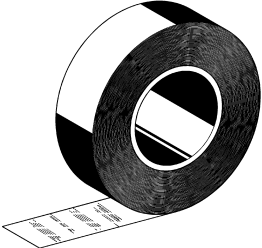
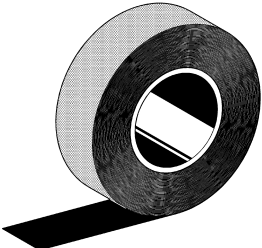

Produkt	Artikel	Pakirano	Artikel-št.
<b>Izolacijski trak Anker</b> 	<b>Gruppe: 7523</b>		
	rot	50	109789
	blau	50	109725
<b>Cevak ISA</b> 	<b>Gruppe: 3711</b>		
	15 -20	42	405560
	18 -20	42	405561
	22 -20	36	405562
	28 -20	30	405563
	35 -20	25	405564
	42 -20	20	405565
	48 -20	20	405566
	60 -20	15	405567
	28 -30	16	405568
	34 -30	16	405569
	42 -40	9	405570
	48 -40	9	405571
	54 -40	8	405572
	60 -40	6	405573
<b>Lepilni trak Alltape</b> 	<b>Gruppe: 7521</b>		
	hellgrau 50	4	109345
	dunkelgrau 50	4	109363
	schwarz 50	4	405103
	gelb 30	5	405067
	gelb 50	4	405076
	rot 50	4	405031

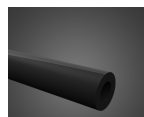
Produkt	Artikel	Pakirano	Artikel-št.
<b>Lepilni trak Sikla-Plast</b> 	<b>Gruppe: 7522</b>		
	hellgrau 30	22	405993
	hellgrau 50	14	135854
	dunkelgrau 30	22	135872
	dunkelgrau 50	14	135881
<b>Lepilni trak Coroplast 918 Alu</b> 	<b>Gruppe: 7521</b>		
	918/50	24	404401
	918/75	16	404410
<b>Lepilni trak Coroplast 910 Alu-SE</b> 	<b>Gruppe: 7521</b>		
	910 SE/50	24	126348
	910 SE/75	16	126339
<b>Lepilni trak GKB</b> 	<b>Gruppe: 7521</b>		
	grau	24	411557
	schwarz	24	411558

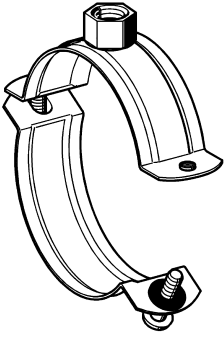
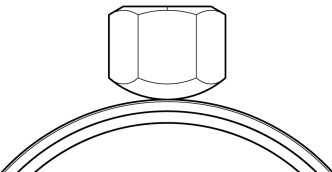

Produkt	Artikel	Pakirano	Artikel-št.	
<b>Vpenjalni nastavek SPA 5P VA</b>  	<b>Gruppe: 1731</b>			
	M12	20	803802	
	M16	20	803803	
<b>Objemka vijajna SRS VA</b>    13 - 73 mm M8  75 - 169 mm M10  	<b>Gruppe: 1722</b>			
	13 - 18	$\frac{1}{4}'' + \frac{3}{8}''$	100	170587
	19 - 22	$\frac{1}{2}''$	100	170602
	27 - 30	$\frac{3}{4}''$	100	170611
	32 - 36	1"	100	170620
	40 - 44	1 $\frac{1}{4}''$	50	170639
	48 - 54	1 $\frac{1}{2}''$	50	170648
	60 - 66	2"	50	170657
	68 - 73	-	25	173342
	75 - 80	2 $\frac{1}{2}''$	25	170666
	84 - 89	3"	25	170675
	102 - 108	-	25	173351
	110 - 115	4"	25	170684
	129 - 140	5"	25	110882
	159 - 169	6"	25	110883

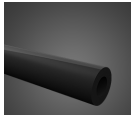

Produkt

Artikel

Pakirano

Artikel-št.

**Objemka vijačna SRS VA z oblogo**

**Gruppe: 1722**

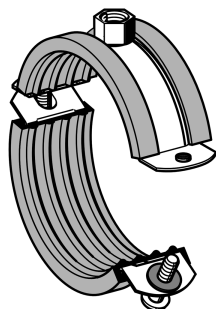

12 - 64 mm  
M8

67 - 170 mm  
M10

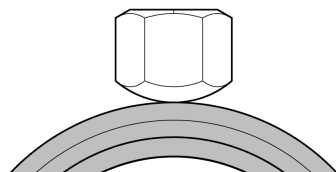

1/4"	12 - 15	100	170693
3/8"	15 - 19	100	170709
1/2"	20 - 23	100	170718
3/4"	25 - 28	100	170727
1"	32 - 35	100	170736
1 1/4"	40 - 45	50	170745
1 1/2"	48 - 52	50	170754
-	52 - 58	50	173360
2"	60 - 64	50	170763
-	67 - 72	25	173369
2 1/2"	73 - 80	25	170772
3"	86 - 91	25	170781
-	102 - 108	25	173378
4"	110 - 115	25	170790
5"	135 - 143	25	110884
-	149 - 161	25	110885
6"	162 - 170	25	110886

**Objemka Stabil D - VA**

**Gruppe: 1739**

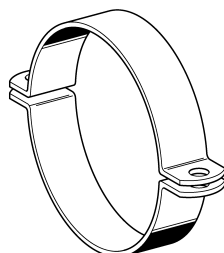

15 - 19	3/8"	50	145723
25 - 30	3/4"	50	145741
31 - 35	1"	50	145750
36 - 41		50	145769
40 - 45	1 1/4"	50	145778
48 - 53	1 1/2"	50	145787
54 - 59		50	145796
60 - 65	2"	50	145802
67 - 72		25	145811
76 - 81	2 1/2"	25	145820
82 - 87		25	145839
88 - 93	3"	25	145848
102 - 108		25	145866
110 - 116	4"	25	145875
124 - 129		25	145893
159 - 165	6"	10	145936
167 - 173		10	145945
176 - 182		10	145954
199 - 205		10	145972
210 - 219	8"	10	414733
247 - 253		10	413725
271 - 277	10"	10	413734
312 - 318		10	413743
322 - 329	12"	10	413752

Produkt

Artikel

Pakirano

Artikel-št.

**Objemka Stabil D-1G VA**

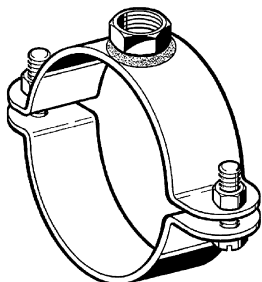

**Gruppe: 1740**

31 - 35	1"	M10	50	145121
36 - 41		M10	50	145130
48 - 53	1 1/2"	M10	50	145158
67 - 72		M10	50	145185
82 - 87		M12	25	145352
94 - 98		M12	25	414112
102 - 108		M12	25	145228
133 - 140	5"	M16	10	145264
149 - 155		M16	10	145273
159 - 165	6"	M16	10	145282
167 - 173		M16	10	145291
176 - 182		M16	10	145307
188 - 194		M16	10	145316
199 - 205		M16	10	145325
210 - 219	8"	M16	10	414193
230 - 236		M16	10	414724
271 - 277	10"	M16	10	414688
312 - 318		M16	10	414697
322 - 329	12"	M16	10	414706

**Objemka Stabil D-1G VA z oblogo**

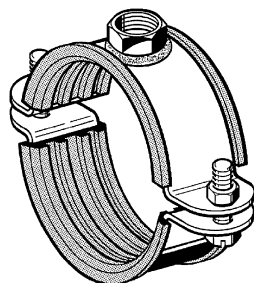

**Gruppe: 1741**

14 - 18	3/8"	M8	50	144856
19 - 23	1/2"	M8	50	144865
24 - 28	3/4"	M10	50	144874
29 - 33		M10	50	144883
33 - 37	1"	M10	50	144892
40 - 45	1 1/4"	M10	50	144908
47 - 52	1 1/2"	M10	50	144917
53 - 58		M10	50	144926
60 - 65	2"	M10	50	144935
67 - 72		M12	25	144944
73 - 78	2 1/2"	M12	25	145088
86 - 90	3"	M12	25	144962
100 - 106		M12	25	144971
124 - 129		M16	25	144999
131 - 137		M16	10	145006
138 - 144	5"	M16	10	145015
148 - 154		M16	10	145024
165 - 171	6"	M16	10	145042
177 - 183		M16	10	145051
188 - 194		M16	10	145060
199 - 208		M16	10	414904
219 - 225	8"	M16	10	145079
236 - 242		M16	10	414913
260 - 266		M16	10	414922
301 - 307		M16	10	414931

Produkt

Artikel

Pakirano

Artikel-št.

**Objemka Stabil D-1G VA Silikon**

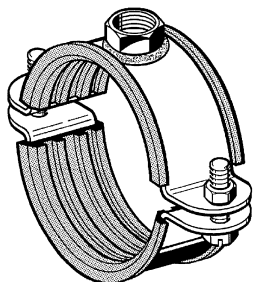

**Gruppe: 1743**

24 - 28	3/4"	M10	50	145398
29 - 33		M10	50	145404
33 - 37	1"	M10	50	145413
60 - 65	2"	M10	50	145459
73 - 78	2 1/2"	M12	25	145477
86 - 90	3"	M12	25	145495
100 - 106		M12	25	145501
124 - 129		M16	25	145529
138 - 144	5"	M16	10	145547
148 - 154		M16	10	145556
156 - 162		M16	10	145565
165 - 171	6"	M16	10	145574
177 - 183		M16	10	145583
188 - 194		M16	10	145592
199 - 208		M16	10	414508
219 - 225	8"	M16	10	145608
236 - 242		M16	10	414517
260 - 266		M16	10	414526
301 - 307		M16	10	414535
311 - 318		M16	10	414544

**Objemka Stabil B-M12 VA**

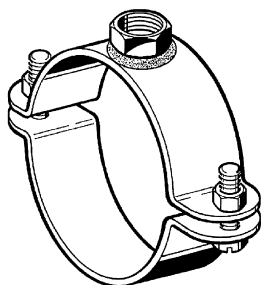

**Gruppe: 1745**

72 - 77			25	405131
82 - 87			25	405132
109 - 114			25	405133
122 - 127			25	405134
133 - 139			10	405135
158 - 164			10	405136
164 - 170			10	405137
200 - 206			10	405138
206 - 215			10	405139
213 - 222			10	405140
247 - 256			10	405141
270 - 279			10	405142
298 - 306			10	405143
309 - 317			10	405144
322 - 331			10	405145



Produkt

Artikel

Pakirano

Artikel-št.

**Streme navojno RUB VA**

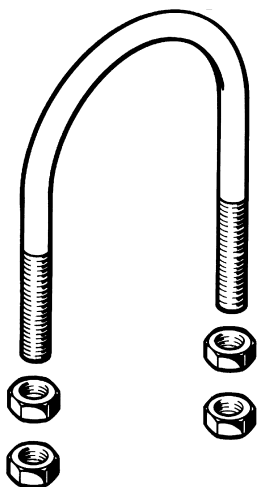

**Gruppe: 1710**

21,3	1/2"	M 8	50	102719
26,9	3/4"	M 8	50	102728
33,7	1"	M 8	50	102737
42,4	1 1/4"	M 8	50	102746
48,3	1 1/2"	M 8	50	102889
60,3	2"	M 10	50	102898
76,1	2 1/2"	M 10	50	102904
88,9	3"	M 10	50	102913
108		M 12	50	102922
114,3	4"	M 12	25	102694
133		M 12	25	102685
139,7	5"	M 12	25	102931
159		M 12	25	102940
168,3	6"	M 12	10	102700
219,1	8"	M 12	10	102959
274,0	10"	M 20	10	102968

**Montažni profil MS VA**

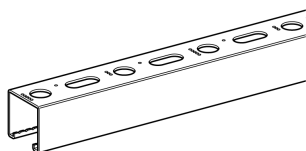

**Gruppe: 1711**

41/21/2,0	6	A4	6	110595
41/41/2,0	2	A4	2	195802
41/41/2,0	6	A4	6	195796
41/62/2,5	6	A4	6	173972
41/41/2,0	D	6 A4	6	195819
41/62/2,5	D	6 A4	6	174143

**Matica kljukasta NT CC 41 VA**

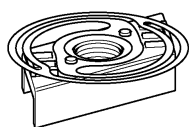

**Gruppe: 1714**

CC 41-M8			50	199305
CC 41-M10			50	199312

Produkt

Artikel

Pakirano

Artikel-št.

**Matica kljukasta NT HZ 41 VA**

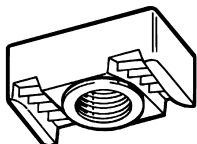

**Gruppe: 1714**

HZ 41-M12	50	182342
HZ 41-M16	50	182351

**Objemka Stabil D-2G/-3G VA**

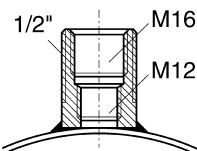
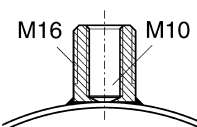
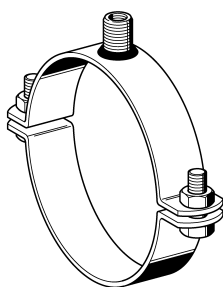

**Gruppe: 1740**

18 - 22	2G	50	172568
24 - 28	2G	50	172577
30 - 34	2G	50	172586
35 - 37	2G	50	172595
40 - 44	2G	50	172604
47 - 51	2G	50	172613
54 - 58	2G	50	172622
59 - 63	2G	50	172631
67 - 71	2G	50	172856
74 - 78	2G	25	172640
81 - 85	2G	25	172865
86 - 90	3G	25	172649
94 - 98	3G	25	172874
102 - 108	3G	25	173153
108 - 114	3G	25	172658
116 - 122	3G	25	172883
133 - 140	3G	10	172667
145 - 152	3G	10	172892
159 - 169	3G	10	172676
170 - 180	3G	10	172901
198 - 207	3G	10	172685
210 - 219	3G	10	172694
222 - 231	3G	10	172910
252 - 256 <sup>1) 2)</sup>	3G	1	401946

**Matica navojna NT VA**

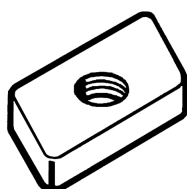

**Gruppe: 1714**

L 41-M8	100	159340
L 41-M10	100	159359

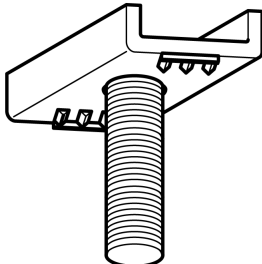
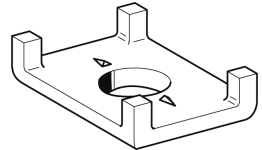
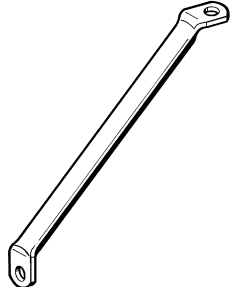
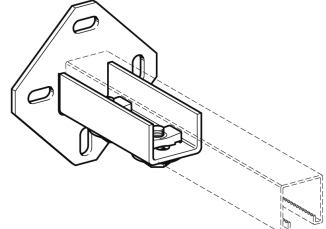
Produkt	Artikel	Pakirano	Artikel-št.
<b>Vijak s kljukasto glavo TBO HZ 41 VA</b> 	<b>Gruppe: 1707</b>		
	HZ 41 M8 x 35	50	111455
	HZ 41 M10 x 35	50	111457
	HZ 41 M12 x 35	50	187454
<b>Ozobje kljukasto HK VA</b> 	<b>Gruppe: 1728</b>		
	41/10	50	178634
	41/12	50	178643
	41/16	50	178652
<b>Opornik STR VA</b> 	<b>Gruppe: 1726</b>		
	550/350	10	171920
<b>Držalo WBD VA</b> 	<b>Gruppe: 1730</b>		
	41/41-62	10	193631



Produkt

Artikel

Pakirano

Artikel-št.

**Objemka Stabil D-2G/-3G z oblogo VA**

**Gruppe: 1741**

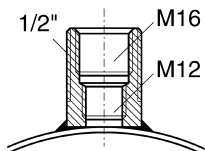
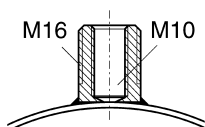
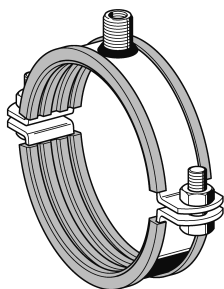

18 - 20	2G	50	172703
21 - 24	2G	50	172712
25 - 29	2G	50	172721
31 - 35	2G	50	172730
38 - 42	2G	50	172739
46 - 50	2G	50	172748
51 - 55	2G	50	172757
58 - 63	2G	50	172766
74 - 78	2G	25	172775
86 - 90	3G	25	172784
100 - 106	3G	25	173162
108 - 114	3G	25	172793
133 - 140	3G	10	172802
158 - 168	3G	10	172811
198 - 207	3G	10	172820
210 - 219	3G	10	172829

**Kotnik montažni MW 90° W Stabil VA**

**Gruppe: 1726**

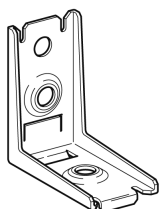

90° W Stabil		25	191702
--------------	--	----	--------

**Kotnik montažni MW VA**

**Gruppe: 1726**

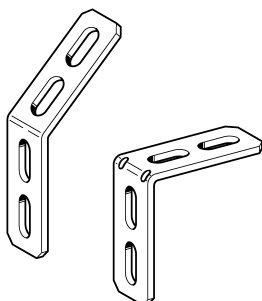

90/90/45°		25	105721
95/95/90°		25	106281

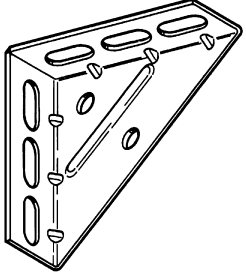
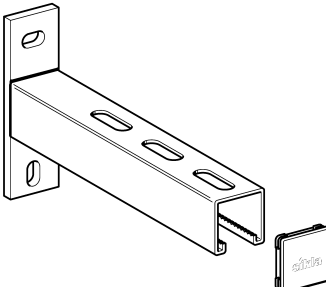
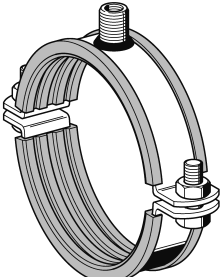
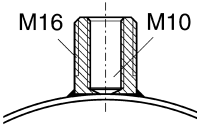
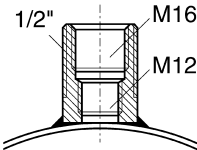
Produkt	Artikel	Pakirano	Artikel-št.	
<b>Konzola kotna WK VA</b> 	<b>Gruppe: 1726</b>			
	100/100	25	118383	
	150/150	25	193655	
<b>Konzola previsna AK VA</b> 	<b>Gruppe: 1754</b>			
	41/41 - 200	10	115520	
	41/41 - 260	10	115539	
	41/41 - 320	10	115548	
	41/41 - 445	10	115557	
<b>Objemka Stabil D-2G/-3G Silikon VA</b>   	<b>Gruppe: 1743</b>			
	18 - 20	2G	50	172919
	21 - 24	2G	50	172928
	25 - 29	2G	50	172937
	31 - 35	2G	50	172946
	38 - 42	2G	50	172955
	46 - 50	2G	50	172964
	51 - 55	2G	50	172973
	58 - 63	2G	50	172982
	74 - 78	2G	25	172991
	86 - 90	3G	25	173000
	100 - 106	3G	25	173072
	108 - 114	3G	25	173009
	133 - 140	3G	10	173018
	158 - 168	3G	10	173027
	198 - 207	3G	10	173036
210 - 219	3G	10	173045	





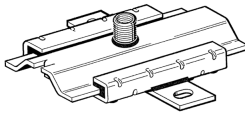
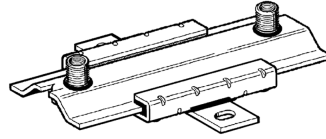
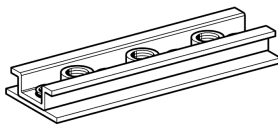
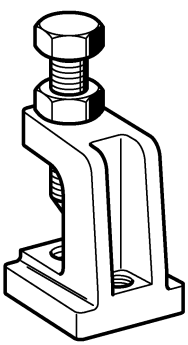
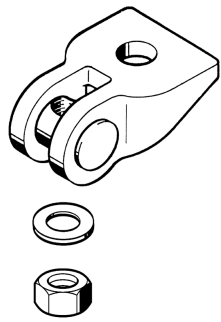

Produkt	Artikel	Pakirano	Artikel-št.
<b>Drsnik GS H3G-PL VA</b>  	<b>Gruppe: 1736</b>		
	H3G-PL	10	170152
	H3G2-PL	10	170134
<b>Drsnik GS 41 VA</b> 	<b>Gruppe: 1736</b>		
	41 - M10	10	190667
<b>Spona za nosilec TCS VA</b> 	<b>Gruppe: 1737</b>		
	TCS 1 M10/M8	50	170231
	TCS 1 M10/M10	50	116568
	TCS 1 M10/M12	50	110766
<b>Zglob univerzalni UG VA</b> 	<b>Gruppe: 1742</b>		
	UG M8	50	171686
	UG M10	50	171695
	UG M12	25	171704
	UG M16	25	171713

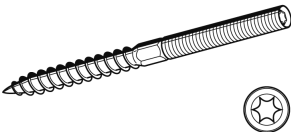
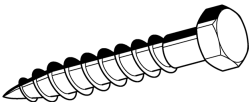
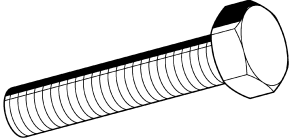

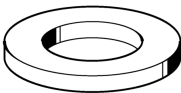
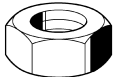
Produkt	Artikel	Pakirano	Artikel-št.
<b>Mufa očesna SCB VA</b> 	<b>Gruppe: 1701</b>		
	M12-13-0°	50	402240
	M12-13-45° K A4	50	402237
	M12-17-45°	25	402243
	M16-17-0°	25	402244
	M16-17-45°	25	402245
	M20-21-45°	10	402252
<b>Vijak hanger brez vezi BSCR VA</b> 	<b>Gruppe: 1715</b>		
	M8 / 80	100	410836
	M10 / 100	100	410845
<b>Vijak šestrobe lesni SKH VA</b> 	<b>Gruppe: 1770</b>		
	8 x 60	200	411475
	8 x 80	100	411484
<b>Vijak šestrobi SKT VA</b> 	<b>Gruppe: 1775</b>		
	M6/25	100	104359
	M8/25	100	146131
	M8/35	100	104669
	M10/20	100	413176
	M10/30	100	104678
	M10/45	100	104377
	M12/30	100	151397
	M12/35	100	146140
	M12/50	100	104368
	M16/25	100	172280
	M16/30	100	172289
	M16/45	50	404968
M16/50	100	151643	

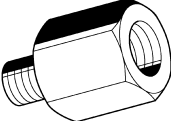
Produkt	Artikel	Pakirano	Artikel-št.
<b>Podložka US VA</b> 	<b>Gruppe: 1772</b>		
	8/125	100	104766
	10/125	100	104775
	12/125	100	104784
	16/125	100	104809
	8/9021	100	172019
	8/40	100	111865
	10/9021	100	171740
	10/40	100	111866
	12/30	100	405320
	12/40	100	111867
	16/9021	100	172028
	<b>Matica šestroba NT VA</b> 	<b>Gruppe: 1771</b>	
M6		100	104696
M8		100	104702
M10		100	104711
M12		100	104720
M16		100	104748
<b>Podaljsek navojni AD IG/IG VA</b> 	<b>Gruppe: 1732</b>		
	M8	100	104818
	M10	100	104827
	M12	50	104836
	M16	50	104845
	M12 - rund	50	402261
<b>Kos prehodni AD IG/AG VA</b> 	<b>Gruppe: 1713</b>		
	12/8	50	113652
	12/10	50	113661

Produkt	Artikel	Pakirano	Artikel-št.	
<b>Navojna palica GST VA</b>  	<b>Gruppe: 1717</b>			
	M8 1 m	1	104854	
	M10 1 m	1	104863	
	M12 1 m	1	104872	
	M16 1 m	1	104881	
	M20 1 m	1	500966	
	M8 3 m	3	172253	
	M10 3 m	3	113914	
	M12 3 m	3	113915	
	M16 3 m	3	113916	
	M20 3 m	3	400966	
	<b>Gruppe: 1709</b>			
	<b>Navojna cev GR VA</b> dolžine: 2 m  	G 1/2"	2	170347
		G 3/4"	2	170356
G 1"		2	170365	
<b>Gruppe: 1738</b>				
<b>Vijak sidrni VMZ-A A4</b>  	VMZ-A 80 M12-25/125	10	112647	

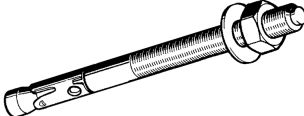
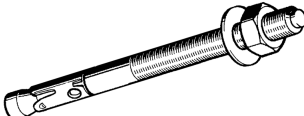
Produkt	Artikel	Pakirano	Artikel-št.
<b>Sidro AN BZ plus A4</b>	<b>Gruppe: 1704</b>		
* = brez potresnega certifikata	8/6/60 s A4 *	100	114159
	8/10/21/75 A4	100	114160
	8/30/41/95 A4	100	114161
	8/50/61/115 A4	100	114162
	10/10/70 s A4 *	50	114163
	10/10/30/90 A4	50	114164
	10/15/35/95 A4	50	114165
	10/30/50/110 A4	50	114166
	10/50/70/130 A4	50	114167
	10/100/120/180 A4	50	114168
	12/15/35/110 A4	25	114169
	12/20/40/115 A4	25	114170
	12/30/50/125 A4	25	114171
	12/50/70/145 A4	25	114172
	16/25/45/145 A4	20	114174
	16/50/70/170 A4	20	114175
<b>Sidro AN BZ3 A4</b>	<b>Gruppe: 1755</b>		
	8/5/60 s A4	100	419050
	8/10/65 s A4 <sup>1)</sup>	100	419051
	8/10/20/75 A4 <sup>1)</sup>	100	419052
	8/15/25/80 A4 <sup>1)</sup>	100	419053
	8/30/40/95 A4 <sup>1)</sup>	100	419054
	8/50/60/115 A4 <sup>1)</sup>	100	419055
	8/100/110/165 A4 <sup>1)</sup>	50	419056
	10/10/70 s A4	50	419057
	10/20/80 s A4	50	419058
	10/10/30/90 A4	50	419059
	10/15/35/95 A4	50	419060
	10/20/40/100 A4	50	419061
	10/30/50/110 A4	50	419062
	10/50/70/130 A4	50	419063
	10/75/95/155 A4	50	419064
	10/100/120/180 A4	50	419065
	12/10/85 s A4	25	419066
	12/20/95 s A4	25	419067
	12/10/30/105 A4	25	419068
	12/15/35/110 A4	25	419069
	12/20/40/115 A4	25	419070
	12/30/50/125 A4	25	419071
	12/50/70/145 A4	25	419072
	12/65/85/160 A4	25	419073
	12/85/105/180 A4	25	419074
	12/105/125/200 A4	25	419075
	16/15/115 s A4	20	419076
	16/5/25/125 A4	20	419077
	16/15/35/135 A4	20	419078
	16/25/45/145 A4	20	419079
	16/50/70/170 A4	20	419080
	16/80/100/200 A4	10	419081





Produkt

Artikel

Pakirano

Artikel-št.

**Objemka Stabil D-3G z oblogo HCP**

**Gruppe: 1843**

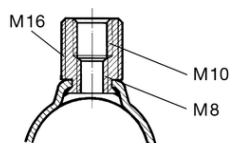
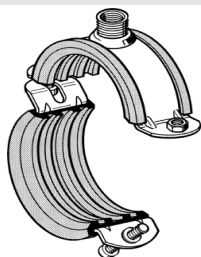

14 – 115 mm:  
M16/M10/M8  
124 – 305 mm:  
1/2"/M16/M12

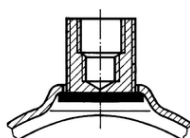

14 – 18	3/8"	M16/M10/M8	50	112249
19 – 23	1/2"	M16/M10/M8	50	112250
24 – 28	3/4"	M16/M10/M8	50	112251
29 – 33	1"	M16/M10/M8	50	112252
33 – 37		M16/M10/M8	50	112253
40 – 45	1 1/4"	M16/M10/M8	50	112254
47 – 52	1 1/2"	M16/M10/M8	50	112255
53 – 58		M16/M10/M8	50	112256
60 – 65	2"	M16/M10/M8	50	112257
67 – 72	M	M16/M10/M8	25	115781
73 – 78	M 2 1/2"	M16/M10/M8	25	115782
79 – 85	M	M16/M10/M8	25	115783
88 – 93	M 3"	M16/M10/M8	25	115784
100 – 106	M	M16/M10/M8	25	115785
108 – 115	M 4"	M16/M10/M8	25	115786
124 – 129	1/2"/M16/M12		10	112266
131 – 137	1/2"/M16/M12		10	112267
138 – 144	5"	1/2"/M16/M12	10	112268
148 – 154		1/2"/M16/M12	10	112269
156 – 162		1/2"/M16/M12	10	112270
165 – 171	6"	1/2"/M16/M12	10	112271
177 – 183		1/2"/M16/M12	10	112272
188 – 194		1/2"/M16/M12	10	112273
196 – 203		1/2"/M16/M12	10	112274
205 – 214		1/2"/M16/M12	10	112275
219 – 225	8"	1/2"/M16/M12	10	112276
244 – 250		1/2"/M16/M12	10	112278
267 – 273	10"	1/2"/M16/M12	10	112280
278 – 284		1/2"/M16/M12	10	112281
299 – 305		1/2"/M16/M12	10	112282
307 – 318	*	1/2"/M16/M12	10	112283

Produkt

Artikel

Pakirano

Artikel-št.

**Objemka Stabil RB-A HCP**

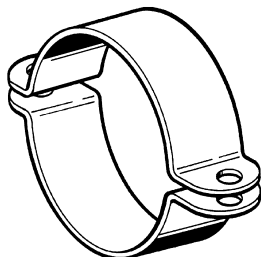

**Gruppe: 1860**

18	14 - 18	25	112790
22	18 - 22	25	112791
27	23 - 27	25	112792
39	35 - 39	25	112794
44	40 - 44	25	112795
49	45 - 49	25	112796
61	57 - 61	25	112797
71	67 - 71	25	112798
77	72 - 77	25	112799
89	84 - 89	25	112800
102	96 - 102	10	112801
109	102 - 109	10	112802
115	109 - 115	10	112803
134	128 - 134	10	112804
140	134 - 140	10	112805
163	157 - 163	10	112806
169	163 - 169	10	112807
194	188 - 194	1	112808
221	215 - 221	1	112809
254	246 - 254	1	112810
266	259 - 266	1	112811
273	266 - 273	1	112812
324	317 - 324	1	112813
356	349 - 356	1	112814
374	366 - 374	1	112815
407	397 - 407	1	112816
429	419 - 429	1	112817
457	447 - 457	1	112818
508	498 - 508	1	112819
530	520 - 530	1	112820
541	531 - 541	1	112821
610	600 - 610	1	112822

**Adapter AD IG/IG HCP**

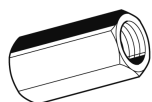

**Gruppe: 1833**

1/2"/M10		10	112163
1/2"/M16		25	112167
1/2"/1/2"		10	112166

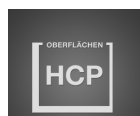

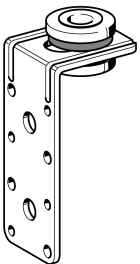
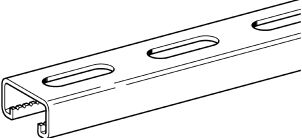
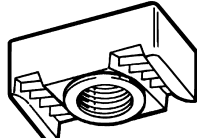
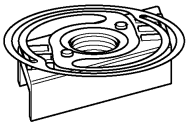

Produkt	Artikel	Pakirano	Artikel-št.
<b>Kotnik kanalni LUW HCP</b> 	<b>Gruppe: 1801</b>		
	SL	100	113931
<b>Montažni profil MS 41 HCP</b> 	<b>Gruppe: 1811</b>		
	41/21/2,0 6	6	193860
	41/41/2,0 6	6	196724
	41/41/2,5 6	6	161497
	41/62/2,5 6	6	199527
	41/21/2,0 D * 6	6	193884
	41/41/2,5 D * 6	6	166748
<b>Matica kljukasta NT HZ 41 HCP</b> 	<b>Gruppe: 1814</b>		
	HZ 41-M10	50	162115
	HZ 41-M12	50	162133
	HZ 41-M16	50	182279
<b>Matica kljukasta NT CC 41 HCP</b> 	<b>Gruppe: 1814</b>		
	CC 41-M6	50	198698
	CC 41-M8	50	198650
	CC 41-M10	50	186284
	CC 41-M12	50	110015

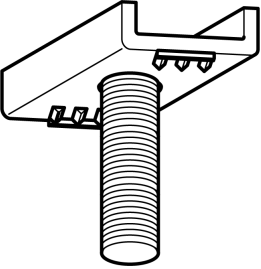
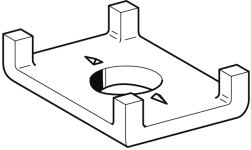
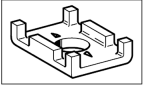
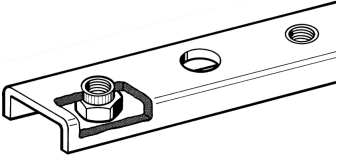
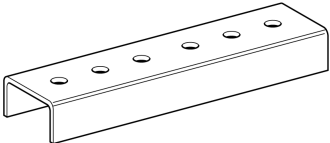

Produkt	Artikel	Pakirano	Artikel-št.
<b>Vijak s kljukasto glavo TBO HZ 41 HCP</b> 	<b>Gruppe: 1809</b>		
	HZ 41 M10 x 35	50	111453
	HZ 41 M12 x 35	50	111454
<b>Ozobje kljukasto HK HCP</b> 	<b>Gruppe: 1828</b>		
	41/10	50	179606
	41/12	50	179615
	41/16	50	179624
<b>Sklop za profil SK HCP</b>  	<b>Gruppe: 1853</b>		
	SK 41/21-31	10	186680
	SK 41/41-45	10	195642
	SK 41-75/75	10	195680
<b>Sklop za profil SK-L HCP</b> 	<b>Gruppe: 1853</b>		
	SK-L	10	198971

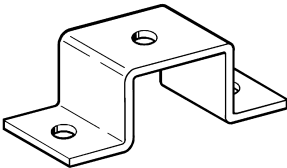
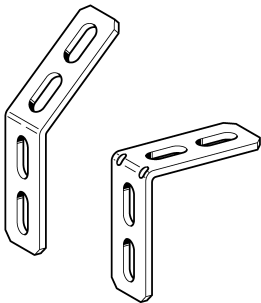
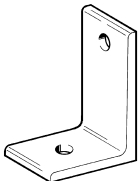
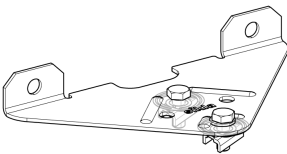
Produkt	Artikel	Pakirano	Artikel-št.
<b>Držalo profila SH HCP</b> 	<b>Gruppe: 1812</b>		
	SH 41/21	50	189992
	SH 41/41	50	183116
	SH 41/41 D	10	183143
	SH 41/62	25	113917
	SH 41-75/75	25	183134
<b>Kotnik montažni MW HCP</b> 	<b>Gruppe: 1826</b>		
	90/90/45°	25	162045
	95/95/90°	25	162036
<b>Kotnik montažni MW S HCP</b> 	<b>Gruppe: 1826</b>		
	60/40/90°	25	162063
	90/60/90°	25	162072
<b>Bočna ojačitev CFB HCP</b> 	<b>Gruppe: 1825</b>		
	CFB CC41	10	803641
	CFB 41	10	803643

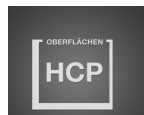

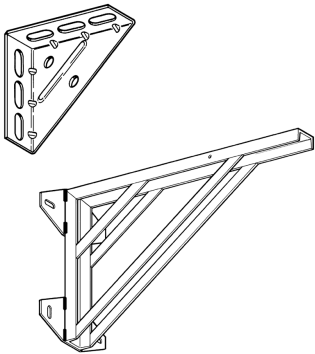
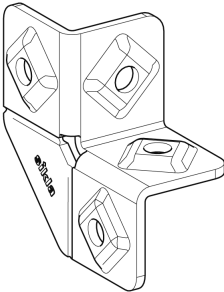
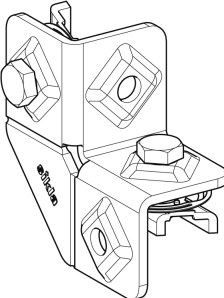
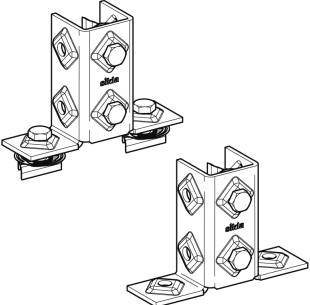

Produkt	Artikel	Pakirano	Artikel-št.
<b>Konzola kotna WK HCP</b>	<b>Gruppe: 1826</b>		
	100/100-40	25	163930
	150/150	25	181685
	300/200	1	162531
	550/350	1	162610
	725/400	1	151041
	880/550	1	151050
<b>Kotni spojnik EW 41-1 HCP</b>	<b>Gruppe: 1852</b>		
	EW 41-1	25	117351
<b>Kotni spojnik EV CC 41-1 HCP</b>	<b>Gruppe: 1852</b>		
	EV CC 41-1	25	117352
<b>Kotni spojnik EV CC 41-2 HCP</b>	<b>Gruppe: 1852</b>		
	EV CC 41-2	10	117457
	EV CC 41-2 W	10	117459

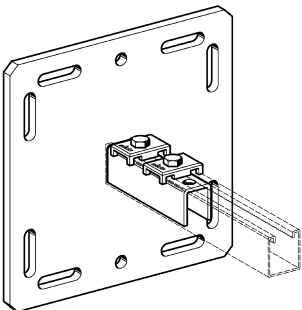
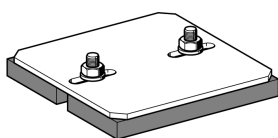
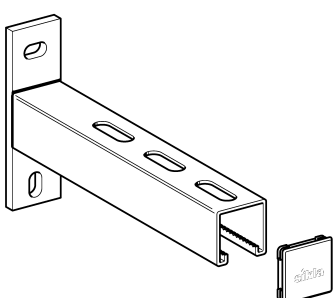
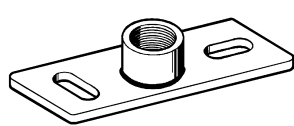

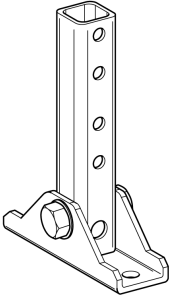
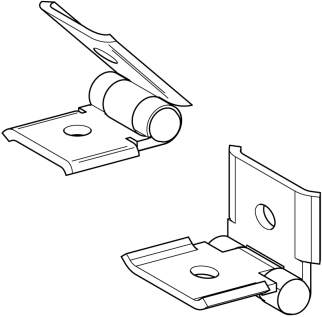
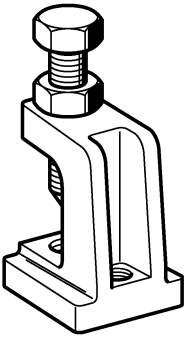

Produkt	Artikel	Pakirano	Artikel-št.
<b>Držalo WBD-C HCP</b> 	<b>Gruppe: 1856</b>		
	41/41-45 C0	1	179498
	41-75/75 C0	1	179507
	41/41-45 D C0	1	179561
<b>Podnožje SHB HCP</b> 	<b>Gruppe: 1877</b>		
	SHB 160	10	113117
	SHB 300	1	113118
	SHB 450	1	113119
	SHB 600	1	113120
	SHB 41-1	10	198902
SHB 41-2	5	198919	
<b>Konzola previsna AK HCP</b> 	<b>Gruppe: 1854</b>		
	41/41 - 320	10	181667
	41/41 - 570	10	181676
	41/41 - 820	1	161479
	41/62 - 570	10	180128
	41/62 - 820	1	180137
	41/21 D - 320	10	180146
	41/21 D - 570	10	180155
	41/21 Dq - 320	10	180164
	41/21 Dq - 570	10	190424
<b>Osnovna plošča GPL HCP</b> 	<b>Gruppe: 1827</b>		
	Stabil M10	50	112684
	Stabil M12	50	112685
	Stabil M16	50	112686
	Stabil R 1/2"	50	112683
GPL Stabil R 1/2"-100	25	183791	

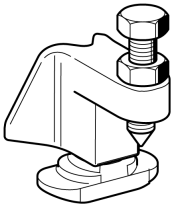
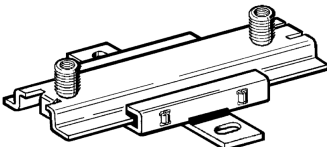
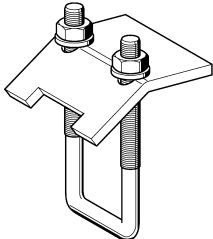
Produkt	Artikel	Pakirano	Artikel-št.
<b>Zglob JOI 41 T HCP</b> 	<b>Gruppe: 1842</b>		
	JOI 41 T	20	197615
<b>Zglob JOI 41 HCP</b> 	<b>Gruppe: 1842</b>		
	JOI 41 V	50	198049
	JOI 41 Z	50	199244
<b>Spona za nosilec TCS HCP</b> 	<b>Gruppe: 1837</b>		
	TCS 1 M10	50	162151
	TCS 2 M12	25	117327

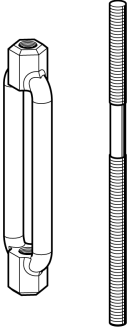
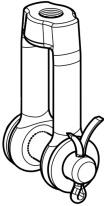
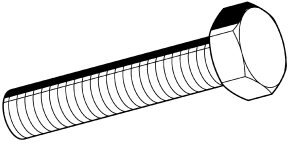

Produkt	Artikel	Pakirano	Artikel-št.
<b>Spona za nosilec TCS 41 HCP</b>	<b>Gruppe: 1837</b>		
	TCS 41	50	110003
			
<b>Drsnik GS 2G-PL HCP</b>	<b>Gruppe: 1836</b>		
	2G2-PL	25	114594
			
<b>Streme vpenjalno SB 41 HCP</b>	<b>Gruppe: 1831</b>		
	41 - M10	20	113879
			
<b>Vpenjalni nastavek SPA 5P HCP</b>	<b>Gruppe: 1831</b>		
	M12	20	114880
	M16	20	114881
			

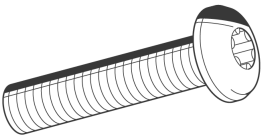
Produkt	Artikel	Pakirano	Artikel-št.
<b>Vpenjalni nastavek SPA 5P AU HCP</b> 	<b>Gruppe: 1831</b>		
	M12 AU	20	115034
	M16 AU	20	115035
<b>Vpenjalni komplet SPZ HCP</b> 	<b>Gruppe: 1878</b>		
	SPZ M10	10	116573
	SPZ M12	10	116574
	SPZ M16	10	116575
<b>Navojno držalo GWB HCP</b> 	<b>Gruppe: 1878</b>		
	GWB M10	10	113053
	GWB M12	10	113054
	GWB M16	10	113055
<b>Vijak šestrobi SKT HCP</b> 	<b>Gruppe: 1870</b>		
	M10/25	100	162568
	M10/40	100	162577
	M12/25	100	162586
	M12/30	100	164144
	M12/40	50	162595
	M12/60	50	164153
	M12/80	50	164162
	M12/100	50	164171
	M16/50	100	162601
	M16/80	25	164180
	M16/100	25	171866

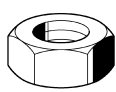
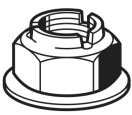
Produkt	Artikel	Pakirano	Artikel-št.
<b>Vijak s prirobnico SCR FLA HCP</b> 	<b>Gruppe: 1875</b>		
	TT M10 x 30	100	116479
	TT M10 x 60	100	116817
<b>Podložka US HCP</b> 	<b>Gruppe: 1872</b>		
	10/125	100	162346
	12/125	100	162355
	16/125	100	179156
	10/40	100	162373
	12/40	100	162364
<b>Matica šestroba NT HCP</b> 	<b>Gruppe: 1871</b>		
	M10	100	162391
	M12	100	162382
	M16	100	163019
<b>Matica prirobna NT SEC HCP</b> 	<b>Gruppe: 1876</b>		
	M8	50	113062
	M10	50	113063

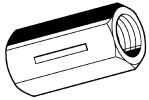
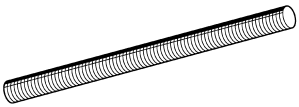
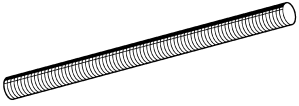
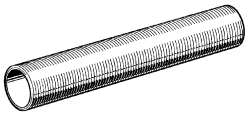
Produkt	Artikel	Pakirano	Artikel-št.
<b>Matica podaljšana AD IG/IG HCP</b>  	<b>Gruppe: 1832</b>		
	M10 x 30	100	116700
	M12 x 35	50	116701
	M16 x 40	50	116702
<b>Navojni zatič GST HCP</b>  	<b>Gruppe: 1816</b>		
	M10/40	100	162407
	M10/70	100	162416
	M10/110	100	162425
	M12/70	100	162443
	M12/110	100	162452
	M12/200	100	162461
	M12/250	100	180686
	M12/300	100	180695
	M12/400	100	180713
<b>Navojna palica GST HCP</b>  	<b>Gruppe: 1817</b>		
	M10 1 m	25	114842
	M10 3 m	30	116569
	M12 1 m	25	114843
	M12 3 m	30	116570
	M16 1 m	10	114844
	M16 3 m	15	116571
<b>Navojna cev GR HCP</b> dolžine: 2 m  	<b>Gruppe: 1813</b>		
	G 1/2"	2	110717

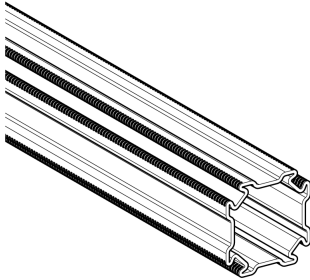
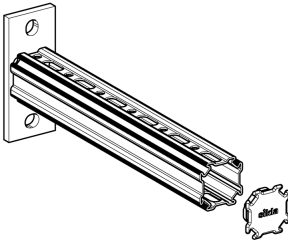
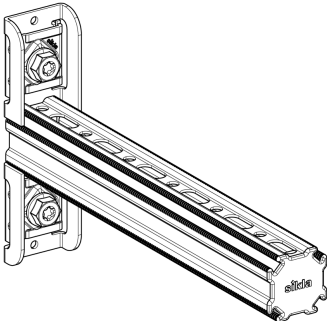
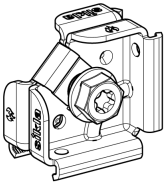

Produkt	Artikel	Pakirano	Artikel-št.
<b>Montažni profil PRO 46</b> 	<b>Gruppe: B100</b>		
	PRO 46	6	802156
	PRO 46	2	802157
	PRO 46-P	6	802152
	PRO 46-P	2	802153
<b>Konzola previsna AK 46-P</b> 	<b>Gruppe: B101</b>		
	AK 46-P - 200	10	802209
	AK 46-P - 400	10	802210
	AK 46-P - 600	1	802211
	AK 46-P - 800	1	802212
	AK 46-P - 1000	1	802213
<b>Konzola previsna AK CC 46-P</b> 	<b>Gruppe: B101</b>		
	AK CC 46-P - 200	10	802214
	AK CC 46-P - 400	10	802215
	AK CC 46-P - 600	1	802216
	AK CC 46-P - 800	1	802217
	AK CC 46-P - 1000	1	802218
<b>Spojnik CN 46</b> 	<b>Gruppe: B103</b>		
	CN 46	25	803545



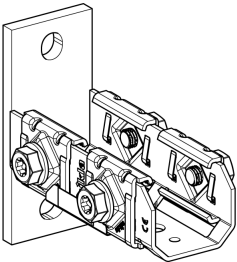
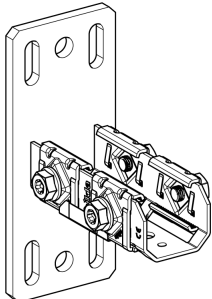
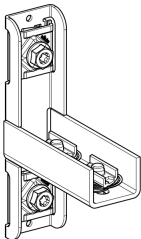
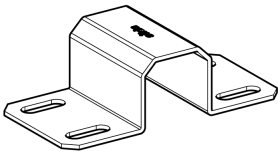

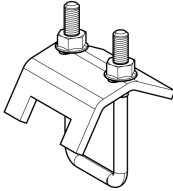
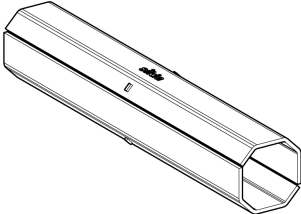
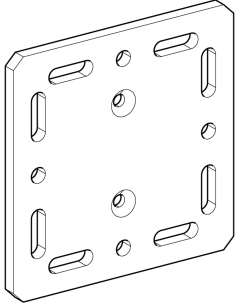
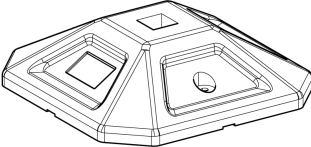
Produkt	Artikel	Pakirano	Artikel-št.
<b>Držalo WBD 46</b> 	<b>Gruppe: B102</b>		
	WBD 46	5	803544
<b>Adapter montažni profil 80/100 na PRO 46</b> 	<b>Gruppe: B104</b>		
	MPA F 80-46	5	802150
	MPA F 100-46	5	802151
<b>Adapter montažni profil 27/41 na PRO 46</b> 	<b>Gruppe: B105</b>		
	SA PRO 46-27	10	803541
	SA PRO 46-41	10	803542
<b>Montažno držalo profila MPH 46</b> 	<b>Gruppe: B106</b>		
	MPH F 80 - 46	15	802546
	MPH F 100 - 46	10	802547
	MPH PRO 46 - 41	10	803866
	MPH MS 41 - 46	10	803867
	MPH PRO 46 W	20	805343

Produkt	Artikel	Pakirano	Artikel-št.
<b>Streme vpenjalno SB 46</b>	<b>Gruppe: B107</b>		
	SB 46 M10	20	803870
			
<b>Adapter PK 46</b>	<b>Gruppe: B108</b>		
	PK 46	1	802159
			
<b>Adapterska plošča AP 46</b>	<b>Gruppe: B109</b>		
	AP 46 80-120	1	802158
			
<b>Podnožje SHB SQF 46</b>	<b>Gruppe: B130</b>		
	SHB SQF 46 - 350	1	803651
	SHB SQF 46 - 500	1	803652
			

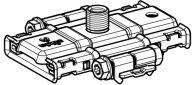
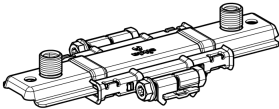
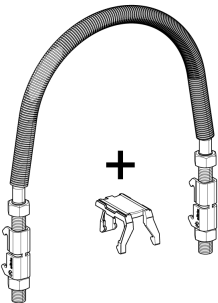
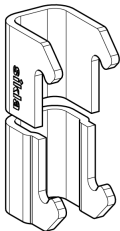

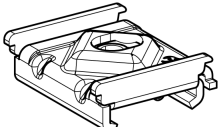
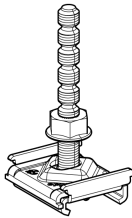
Produkt	Artikel	Pakirano	Artikel-št.
<b>Drsnik GS H3G-PL 46</b>    	<b>Gruppe: B111</b>		
	H3G-PL 46	10	803868
	H3G2-PL 46	10	803869
<b>Streme navojno RUB 46</b>  	<b>Gruppe: B112</b>		
	21,3 mm	50	805053
	26,9 mm	50	805054
	33,7 mm	50	805055
	42,4 mm	50	805056
	48,3 mm	50	805057
	60,3 mm	50	805058
	76,1 mm	50	805059
	88,9 mm	50	805060
	108 mm	25	805061
	114 mm	25	805062
	133 mm	25	805063
	139 mm	25	805064
	159 mm	10	805065
	168 mm	10	805066
219 mm	10	805067	
<b>Klema za objemke MPK 46</b>  	<b>Gruppe: B113</b>		
	M8	200	803862
	M10	100	803863
	M12	100	803864
	M16	100	803865

Produkt	Artikel	Pakirano	Artikel-št.
<b>Blok PBH 46</b>  	<b>Gruppe: B114</b>		
	M6 *	25	803546
	M8	25	803547
	M10	25	803548
	M12	25	803549
	M16	25	803550
	1/2"	25	803551
<b>Montažni komplet PBS 46</b>  	<b>Gruppe: B115</b>		
	M8 x 50	25	803552
	M8 x 90	25	803553
	M8 x 140	25	803554
	M10 x 50	25	803555
	M10 x 90	25	803556
	M10 x 140	25	803557
<b>Zaključna kapica ADK 46</b>  	<b>Gruppe: B117</b>		
	ADK 46	50	802148

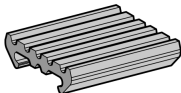
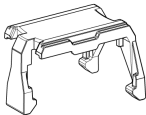
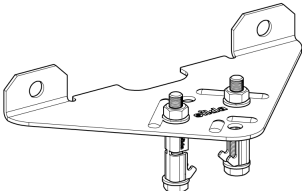

Produkt	Artikel	Pakirano	Artikel-št.
<b>Profilna guma SAL 46</b>	<b>Gruppe: B118</b>		
	SAL 46	30	802160
	SAL 46 / L50	-	802161
			
<b>Drсна podloga GA 41-46</b>	<b>Gruppe: B116</b>		
	GA 41-46	50	803871
			
<b>Bočna ojačitev CFB 46</b>	<b>Gruppe: B136</b>		
	CFB 46	10	803640
			
<b>Križni drsniK KGL 46</b>	<b>Gruppe: B111</b>		
	KGL H3G-PL 46	10	807435
	KGL H3G2-PL 46	10	807436
